

IISc/SSCU/2021/SP/CR-02

Request for quote (RFQ) from domestic (India-based) manufacturers, Indian OEM or its authorized Indian distributor for the design, supply, commissioning and validation of Class-1000 and Class-10,000 Clean Rooms

Tender Opening Date: 8 April 2021

Date for Pre-Bid Clarifications: 19 April 2021

Date for Posting for Final Revised Tender: 21 April 2021

Date for Final Bid Submission: 5 PM, 3 May 2021.

The tender notification concerns the design, supply, commissioning and validation of class-1000 and class-10000 clean room sections in the Chemical Sciences Division at the Indian Institute of Science, Bangalore. The commissioning also includes certain equipment as given in the specifications. Your quotation should clearly indicate the terms of delivery, installation, delivery and installation schedule, estimated date for commissioning and validation, and payment terms. **The tender should be submitted in two separate sealed envelopes - one containing the technical bid and the other containing the commercial bid, both of which should reach us, duly signed on or before 5 PM, 3 May 2021.**

Note: The Bidder should belong to either class 1 or class 2 supplier distinguished by their "local content" as defined by recent edits to GFR. They should mention clearly which class they belong to in a cover letter

- a) Class 1 supplier: Goods and services should have local content of equal to or more than 50%.*
- b) Class 2 supplier: Goods and services should have local content of equal to or more than 20 % and less than 50%.*

Purchase preference as defined by the recent edits to GFR (within the "margin of purchase preference") will be given to Class-1 supplier.

The quotations should be on FOR-IISc Bangalore basis in INR only.

The bids should be addressed to:

*The Chairman,
Solid State and Structural Chemistry Unit
Indian Institute of Science (IISc)
Bengaluru, India - 560012.*

The sealed bids should be sent to:

*Prof. Satish Patil
Solid State and Structural Chemistry Unit
Indian Institute of Science (IISc)
Bengaluru, India - 560012.
Ph: +91-80-2293-2651; email: spatil@iisc.ac.in*

Emails regarding any technical clarifications/queries should be sent to: spatil@iisc.ac.in and phani@iisc.ac.in

Table of Contents		
S.No.	Section Title	Page Number
1.	Technical Specifications and Requirements	3-21
2.	List of Approved Makes	22-25
3.	Terms and Conditions	26-27
4.	Laboratory Floor Plans	28-29
5.	Check List to be Submitted along with Technical Bid	30
6.	Check List to be Submitted along with Commercial Bid	31
7.	Annexure-1: Details of the Bidder	32
8.	Annexure-2: Declaration regarding experience	33
9.	Annexure-3: Declaration regarding track record	34
10.	Annexure – 4: Declaration for acceptance of terms and conditions	35
11.	Annexure-5: Technical Compliance Sheet	36-64
12.	Annexure-6: BOQ Class 1000 Clean Room (Note that pricing information SHOULD be masked when submitting this annexure with Technical Bid)	65-66
13.	Annexure-7: BOQ Class 10000 Clean Room (Note that pricing information SHOULD be masked when submitting this annexure with Technical Bid)	67
14.	Annexure 8: Make and Manufacturer Details	68-72

Technical Specifications and Requirements

I. Broad Requirements and Usage

We are seeking to install two state-of-the-art clean room facilities where one is a Class-1000 clean room and the other a Class-10000 clean room section with related accessories as mentioned in this document. The clean rooms are intended for deposition of metal and metal oxide thin films, thin films of organic materials, processing of substrates and device fabrication using photolithography under a controlled environment. Therefore, the following broad technical criteria are to be met by any quotation submitted under this tender notice:

- I.1.* The construction of clean room spaces must meet standard cleanroom specifications in addition to the specifications mentioned in this tender document.
- I.2.* The clean rooms must maintain air quality, temperature and humidity specifications under normal usage with up to 5 users working simultaneously in addition to the specified equipment load.
- I.3.* Installation should be modular to facilitate any changes that might be needed to accommodate new equipment in the future.
- I.4.* User training on basic maintenance and troubleshooting must be provided.
- I.5.* Materials used in the construction of clean room, fume hoods and clean room benches including but not limited to polypropylene should all be clean room fire retardant grade materials. The fire propagation index (FPI) and smoke development index (SDI) of relevant materials (especially polypropylene) being used in the design should be provided.
- I.6.* ESD Flooring should be chosen such that the total resistance of the floor should be greater than 1 M Ω and less than 10 M Ω . Grounding of the floor is optional.
- I.7.* *The vendor must use components/parts manufactured by the list of approved manufacturers only. If equivalent components from manufacturers that are not in the approved list are to be used, additional documentation providing enough evidence that all technical specifications are met should be enclosed along with the technical bid.*
- I.8.* The specifications/numbers/data provided in this technical document are to be taken for preparing a BOQ. The vendors should treat the specified quantities/numbers/data for various segments of the cleanroom and utility as a guideline to initiate their calculations. The vendors are supposed to provide IISc with an estimate of each and every component related to the cleanroom and its utility during their bid submittal. If the vendor estimates that higher quantities than requested are necessary, the excess should be quoted as an option. However, if the vendor estimates that lower quantities of a particular item are sufficient, the quotation should still include the costing for minimum requested quantities.
- I.9.* Suitable clean room layout drawings should be provided along with the technical bid.
- I.10.* Any additional construction for utilities placed on the terrace floor may be quoted as an option.

II. Specifications and Requirements for Class-1000 Clean Room Section

II.1. Layout and Construction

- II.1.1. **Floor Area:** ~25 sq. m. Refer appendix for floor plan (Section VI.1).
- II.1.2. **Wall panels:** The wall panelling must be modular, interlocking type and double skinned with both sides being powder coated GI (class-1000 clean room grade) with a skin thickness of at least 0.8 mm and powder coating thickness of 60 microns. Wall panels with built-in air raisers for extracting return air from the cleanroom are preferable. Such panels must be at least 100 mm in thickness with polyurethane foam (PUF) infilling with a density greater than or equal to 40 kg/m³. The panels must be reinforced along the periphery. Panels must be mounted and secured on suitable tracks. All joints must be sealed with cleanroom compatible neutral grade silicone sealant. All cut-outs must be covered with a suitable track. If wall panel design other than those with built-in air risers are provided, suitable technical or economy of cost justification must be given. In such alternate designs, skin thickness must be at least 0.8 mm and the powder coating thickness should be 60 microns or greater, and the panel thickness must be 50 mm or greater. The material of the panels must be clean-room compatible powder coated GI.
- II.1.3. **Ceiling:** The cleanroom ceiling must be at a height of 2500 mm or higher from the floor of the cleanroom. The ceiling height of the lab space housing the Class-1000 cleanroom is ~5250 mm. The ceiling panelling must be modular, and double skinned with both sides being powder coated GI (class-1000 clean room grade) with a skin thickness of at least 0.8 mm and powder coating thickness of at least 60 microns. The panels must be at least 50 mm thick with PUF infilling with a density greater than or equal to 40 kg/m³. The panels must be reinforced along the periphery and mounted on suitable tracks. All joints must be sealed with cleanroom compatible neutral grade silicone sealant. All cut-outs must be covered with a suitable track.
- II.1.4. **Flooring:** The flooring must be anti-skid, hard wearing and electrostatic dissipative and sufficiently thick and dense to bear the weight of equipment. ESD specifications should meet criteria given in I.6. Each tile must be at least 12" X 12" in area, have an ESD material thickness of at least 3 mm. Vinyl as an ESD material is preferred.
- II.1.5. **Covings:** Clean room compatible Aluminum covings must be installed at corner joints of (a) Wall – Wall (b) Wall – Ceiling (c) Wall – Floor. All 3D corners must be installed and must be covered by 3D pieces. All covings must have sufficient conductivity to enable the dissipation of any electrostatic charge built-up on the floor and enable the total resistance to be in the range given in I.6. Other materials such as PVC will be acceptable with suitable justification.
- II.1.6. **Emergency Doors:** One double shutter door (marked as D1 in VI.1) with a width of 1400 mm (each door 700 mm wide) and 2400 mm in height is to be used for emergency exit and for any large equipment movement. The doors must be double skinned with both sides being powder coated GI (class-1000 clean room grade) with a skin thickness of at least 0.8 mm and powder coating thickness of at least 60 microns. The doors must be at least 44 mm in thickness with PUF infill (density > 40 kg/m³). The doors must be flush with the panels when closed and must be fixed to the door frames with concealed stainless-steel double bearing

butt-hinges as per BS7352 specification. The doors must be provided with all required ancillaries like door closer, lock and key, D-handle, push plate, tower bolt all made of SS. Each door must be provided with a view glass of size 0.4m x 0.4m. All doors must open to the outside of the cleanroom and must be provided with a panic bar so that the doors can be quickly opened to exit the cleanroom in case of an emergency. The doors should have concealed type automatic door bottom seals.

- II.1.7. **Access System:** An RFID-based access system should be included. This should be configurable with existing ID cards. The details of the ID cards will be provided at the time of installation. This should be interlocked with an emergency alarm located outside the clean room. The cost for the installation of the emergency alarm is to be quoted.
- II.1.8. **Window modules:** Windows and door vision panels should be formed from double glazed toughened glass composite modules. One view panel (marked as W1 in VI.1) of size 900x900 mm shall be provided in the wall panels. View panel glass shall be at least 5 mm in thickness. View panels shall be fixed flush to both faces of wall panels. No crevices/joints/sloped profiles should be used for fixing the glass. This requirement is to avoid particle contamination and dust accumulation. All windows and door vision panels must filter light with a wavelength of <500 nm. (specification sheets/data sheets for the UV filters must be provided).
- II.1.9. A **positive pressure airlock** (refer VI.1 for dimensions and position) is to be provided at the cleanroom entrance. This is to also serve as a gowning area. The airlock must be constructed out of suitable class-1000 cleanroom compatible materials. It must be provided with access doors of 0.8 m width and 2.1m height that open outward i.e. out of the airlock (ref VI.1). A clean atmosphere, which is compatible for entry into a Class-1000 clean room, must be maintained inside the airlock. Clean air must be provided inside the airlock through hooded HEPA filters (hermetically sealed designs) or dedicated Fan Filter Units. The airlock must have interlocking doors so that only one door can be opened at a time. The locks must automatically disable when any emergency alarm in the cleanroom is triggered to enable quick evacuation of personnel. The airlock must be provided with necessary gown hangers, storage cabinet(s) etc for storing clean room gowns, masks, hairnets, clean room shoes, and other accessories. Suggested location and layout for the storage cabinet is shown in VI.1.

II.2. *Lighting and Electrical installations in Class-1000 cleanroom section*

- II.2.1. Sufficient ultra-violet-filtered, ceiling mounted LED lighting must be provided through-out the cleanroom. **All radiation below 500 nm must be blocked by the UV filters in the lighting systems.** (specification sheets/data sheets for the UV filters must be provided). The lighting must be sufficient to provide 400 lux or greater illumination at 1 m from the cleanroom floor at all points inside the cleanroom. The illumination intensity must be demonstrated before commissioning. The lighting controls must be provided at user accessible locations inside the cleanroom near the user access door. The necessary fittings, wiring from distribution board and switches must also be supplied and installed. A suitable location for the switch board location that minimizes total wiring length can be chosen by the vendor

- II.2.2. 32 numbers of 5/15 A single-phase power points and 4 numbers of 3-phase 32 A power points should be provided. These power points must be distributed over 5 lines each equipped with a suitable rated terminal circuit breaker (MCBs). Each of the power point must be labelled to indicate the line it is connected to. The MCBs are to be housed in a separate power distribution board inside the clean room. The distribution board must be constructed out of cleanroom compatible materials.
- II.2.3. All motors and switchgears required for various items shall generally be all electric. Motors shall be suitable for 1 phase or 3 Phase, 50 Hz, 240 or 415 volts A.C. supply. The AC supply variability could be between +/- 10%. Therefore, the motors should withstand such load fluctuations. If the motor input is not suitable for power fluctuations, a voltage stabilizer should be provided. Electrical supply from electrical panel to respective AHUs/Condensing Units/Dehumidifier must use armoured cables. Any underground cabling must be steel armoured.
- II.2.4. All electrical wiring/cabling must be fire retardant and of a reputed make and must be sufficiently rated to handle the specified loads. The wiring/cabling must be routed through fire-retardant electrical conduits. Inside the clean room, the cables must be routed through appropriately sized fire-retardant PVC dado with partitions for routing cables and positioning power points separately.
- II.2.5. A suitably rated electrical panel must be provided and cables from AHU and other electrical units must be terminated at the panel. Copper lugs should be insulated for cable termination. All bus bars in the panel should be of copper. Incoming cabling termination at the electrical panel will be provided by IISc.
- II.2.6. All wires/cables must be color coded according to applicable electrical wiring standards. The wires must be labelled appropriately at the terminals. All electrical wiring diagrams/drawings with corresponding labels must be provided with installation documents.

II.3. Installation of gas lines and accessories for Class-1000 cleanroom

- II.3.1. Gas distribution lines, one each for ultra-high pure Nitrogen, ultra-high pure Oxygen and ultra-high pure Argon must be installed. *Each gas line must be plumbed from a gas storage bay outside the cleanroom and terminated at a gas manifold inside the cleanroom with at least 3 output lines. Each output line at the manifold must have a diaphragm type shut off valve. The cost of fittings and piping for 5 meters per distribution line is to be included in the scope of this work (3 gas distribution lines with 5 meters per line).* As an option, the vendor must quote cost for laying any additional length of gas lines on a per foot basis.
- II.3.2. The vendor must quote for supply and installation of components for connecting the **3 gas lines** (as mentioned in II.3.1) to gas cylinders, as follows: Each gas line must have a flexible high-pressure SS hose (SS316L core and SS wire braided outer layer) 1 meter in length connected with a **bull nose** appropriate for each gas mentioned in section II.3.1 (bull nose should not have an O-ring seal). The bull nose must be connected to the hose through a **non-return valve**. The SS hose must be connected to a gas pressure regulator through a diaphragm type **shut-off valve**. The regulator must be of all stainless-steel construction capable of handling inlet pressure of 200 bar. Outlet pressure must be adjustable over 0-15 bar. A sample configuration is shown in figure 1. The regulator must be of barstock type with **SS316L diaphragm**. *All sealing materials used inside the regulators/shut-*

off valves must be clean room compatible and be also compatible with the particular gas type and purity grades. The vendor must attach datasheets/specifications for the same.

- II.3.3. Gas tubing must be supported on channel mounted clean room compatible tubing support with provision to carry a total of 5 lines.
- II.3.4. Any unconnected lines must be appropriately terminated with suitable fittings.
- II.3.5. All support structures and fittings inside the cleanroom must be resistant to acids and common organic solvents and must be clean room compatible.
- II.3.6. All gas lines and accessories must be constructed out of high quality SS316L and must be of a reputed make. Compression type seals are acceptable, if compatible with clean room specifications. The RMS roughness of the inner body of the SS tubing must be 10 Ra or better.
- II.3.7. All gas lines must be leak-checked after installation.
- II.3.8. All gas lines must be labelled at appropriate intervals with clearly visible fade-proof labels easily readable by the user. The vendor must also provide drawings of the final gas plumbing layout.

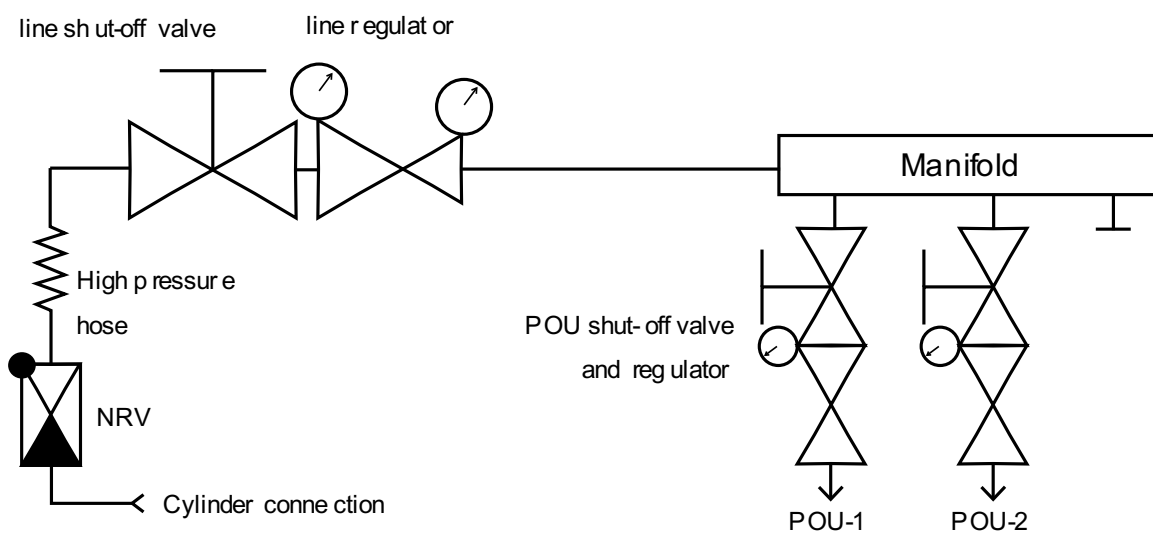

Figure 1: Sample gas line configuration

II.4. Air Handling Unit and related specifications for Class-1000 cleanroom section

- II.4.1. A dedicated recirculating-type Air handling unit/HVAC system must be provided for the class-1000 cleanroom
- II.4.2. The HVAC system must be designed to maintain the class-1000 clean room conditions as specified below:
- 1) Air purity: Particulate concentration of less than 1000 particles of size $< 0.5 \mu\text{m}$ per cubic feet (Class-1000) according to ISO 14644,
 - 2) Room temperature of $22 \pm 2 \text{ }^\circ\text{C}$
 - 3) Relative humidity levels (RH) of $45 \pm 5\%$
 - 4) Differential pressure of 15-20 Pa
 - 5) Number of users: **five** users
 - 6) Estimated equipment load: 6 kW (duty factor = 50% i.e., assume that the space has to be designed for an average equipment heat load of 3 kW)
 - 7) Air flow pattern: Mixed Flow
 - 8) Supply air Design: Negative pressure plenum type airflow using FFU with suitable HEPA filters or hooded HEPA filters-based design.
 - 9) Supply air change rate: a minimum of 130 fresh air changes per hour
 - 10) Supply air velocity: minimum 90 fpm $\pm 20\%$ (0.45 mps $\pm 20\%$)
 - 11) Filter coverage: minimum 30%
 - 12) Fresh air changes per hour: a minimum of 3 fresh air changes per hour
- II.4.3. Air Handling Units (AHU) must be designed to meet specifications in II.4.1 and II.4.2. Fresh air intake must also take into account the exhaust of the fume hood specified in section II.5. AHU must be fitted with appropriate cooling coils, humidifiers, dehumidifiers, pre-filters etc., as required to maintain air temperature and humidity within specification II.4.2. Condenser unit must have a capacity of 6 TR or greater. Air heater module must also be appropriately rated. Only non-toxic, environment friendly refrigerants (R-407C or equivalent) may be used in the condenser units. Details of the refrigerant must be provided. All refrigerant piping and connectors must be made of copper and suitably insulated.
- II.4.4. Treated fresh air needs to be provided in order to compensate for any losses and to also maintain spatial positive pressure in the cleanroom. Precooling coils with suitable pre-filters, volume control dampers (VCDs), mixing box, heaters, mist eliminators etc., should be provided for the fresh air intake of the AHU.
- II.4.5. AHU must be installed on the roof of the building that houses the clean room. Approximate length of the ducting required is about **18 meters**. The vendor may specify optional per meter cost for any extra ducting work.
- II.4.6. Clean air entry into the clean room portion may be either through hooded HEPA filters (hermetically sealed designs) or Fan Filter Units with a negative pressurized plenum. The standard operating cost of the design should be provided. Economical designs that decrease capital and operating costs will be given preference. Clear justifications showing the suitability of the adopted design is required. An air flow diagram must be provided with the technical bid.
- II.4.7. The filters in either of the units of II.4.6 should be modular in design and must be sourced from a reputed Original Equipment Manufacturer (OEM). Sufficient number of these units must be provided to maintain the cleanroom particulate and other specifications (specification II.4.2).

- II.4.8. All units must have HEPA filters manufactured by a reputed OEM. The filters must remove particulates bigger than 0.3 micron with 99.997% or greater efficiency (vendor must provide manufacturer specifications or supporting data). The quote must include details of the OEM. The units must also be equipped with prefilters to remove particulates bigger than 10 microns with 90% or greater efficiency.
- II.4.9. All unit enclosures must have a double skinned corrosion resistant enclosure with a thermal and acoustic insulating infill i.e. PUF of sufficient density (density > 40 kg/m³). Enclosures must be provided with fire and smoke detectors and alarms, inspection doors and necessary inspection lighting. All mounts and frames for the indoor/outdoor units must be painted, be corrosion resistant and must be suitably padded to minimize vibration and noise.
- II.4.10. All ducting must be fabricated according to the latest SMACNA standards and must be cleanroom compatible. Air handling ducts and ducting joints must be made of corrosion resistant material that is resistant to any acid vapors and must have a minimum thickness of 24 gauge (~0.635mm) conforming to the latest SMACNA and cleanroom standards. The clause regarding acid resistance may be relaxed for portions, that the vendor has sufficient reason to believe, would never be exposed to acid vapors. However, the vendor must provide suitable drawings/documentation to support this. Ducting must be low noise and vibration free. All ducting/joints must be tested for leakage before commissioning and the leakage must be within the limits specified in the latest SMACNA standards.
- II.4.11. All ducting must be provided with sufficient thickness of insulation. The insulation must be fire retardant and aluminum faced. Provision must be made for internal cleaning of the ducting at appropriate locations.
- II.4.12. Any grills/diffusers used must be made of extruded anodized aluminum.
- II.4.13. All clamps/fastenings used for the ducting must be corrosion resistant.
- II.4.14. Alarms indicating any faults including fire and smoke alarms and alarms for detecting faults in the air handling system must be installed inside the cleanroom to alert users inside the cleanroom in case of any emergencies.
- II.4.15. An indicator/display unit for clean room temperature, RH and air handling system status along with a gauge showing the differential pressure of the cleanroom must be provided inside the cleanroom.

II.5. *Specifications for wet chemical station-1 for acids-bases*

- II.5.1. Wet chemical station-1 (WCS-1) is meant for wet chemical processing using acids, bases and majorly aqueous solutions.
- II.5.2. WCS-1 should be composed of two parts:
 - Part 1: 600x900x2400 mm (width x depth x height) fume hood with exhaust.*
 - Part 2: 1200x900x2400 mm (width x depth x height) class-100 clean bench without exhaust.*
- II.5.3. WCS-1 must be constructed out of stress relieved high-quality polypropylene sheets of thickness 10 mm or thicker (data regarding residual stress must be provided). Any material being quoted must meet all clean room materials specifications as noted in 1.5. In addition, the material should be compatible with a variety of clean room solvents and photoresist/developer solutions used in a clean room. ***A list of compatible solvents must be given.***

- II.5.4. The fumehood portion of WCS-1 must be provided with a clear transparent height adjustable counter-weight balanced sash made of acid and solvent resistant material that is at least 6mm in thickness. If this is a glass sash, it should be made of toughened laminated glass so that the glass does not shatter and fall to pieces in case of an explosion or breakage.
- II.5.5. The fumehood must have a standard value for face opening at full sash position. The sash opening at full sash position must be provided with the technical bid.
- II.5.6. The fumehood must maintain a face velocity between **90-110 fpm** at half sash position. The fume hood exhaust blower must be suitably rated to maintain air flow rates and all ducting must be made of fire-resistant polypropylene. Fire resistance rating should be clearly mentioned. The quote should also include all necessary accessories, fittings for routing the exhaust duct and installation of the blower.
- II.5.7. The fumehood must have a flat 10 mm thick polypropylene worktop with a skirting of 10 mm height and 25 mm width to contain any spills on the worktop and prevent spilling on the floor. The worktop must be at a standard workable height from the cleanroom floor. The worktop height should be provided with the technical bid.
- II.5.8. One de-ionized (DI) water spray gun made of virgin PTFE with anti-static protection must be provided. This should be centrally located between the fume hood section and the clean bench section so that it is accessible for working in both the sections. The piping for the spray gun must be made of high-quality flexible polypropylene and must not leach contaminants into water (provide data or manufacturer specification sheets). When not in use, the piping must retract and be concealed inside the centrally located space between the fume hood and the clean bench. The piping must be sufficiently long so that the spray gun can reach all portions of the work tops in the fume hood and clean bench sections.
- II.5.9. One Nitrogen gun made of virgin PTFE with anti-static protection must be provided. The nitrogen blow gun should be centrally located between the fume hood section and the clean bench section so that it is accessible for working in both the sections. The piping for the nitrogen gun must be flexible, resistant to acids and common solvents and not outgas or generate particulates (provide specifications or manufacturer data sheet). The piping must have sufficient length to reach all portions of the work tops in the fume hood and the clean bench sections. When not in use, the extra piping must retract and be concealed inside the centrally located space between the fume hood and the clean bench.
- II.5.10. Gas supply lines for nitrogen from gas connection points, which are **3 meters** from the fume hood and clean bench, should be included in the scope of work. These gas lines must be constructed from high-quality SS316L grade stainless steel tubing.
- II.5.11. An in-line gas regulator rated to take an inlet pressure of 15 bar or higher and rated to provide an outlet pressure between 0-15 bar with outlet pressure indication, and a diaphragm type shut-off valve must be provided at an accessible location near the workstation. The pressure regulators are to be SS316L barstock type construction with SS316L diaphragms. All fittings must be suitable for gas pressure control of noncorrosive high purity gases up to grade 5.0 purity (99.999%).
- II.5.12. The part-2 of WCS-1 is a class-100 clean bench. The work area inside the clean bench must be maintained to meet specifications for a class-100 clean bench. Air

must be circulated through suitable filters to maintain laminar down flow in the work area. A positive pressure must be maintained inside the work area to prevent contaminants from the room entering the work area. Acid vapors and particulates that may be present in the return air must be scrubbed before recirculation using suitable filters. *Details of suitable scrubbers, their specifications and maintenance schedule should be clearly given along with the technical bid.* The filter modules must use HEPA filters rated at better than 99.99% efficiency in removing particles bigger than 0.3 micron (provide manufacturer specifications or supporting data).

- II.5.13. The clean bench portion must be provided with a clear transparent height adjustable counter-weight balanced sash made of acid and solvent resistant material that is at least 6 mm in thickness. If this is a glass sash, it should be made of toughened laminated glass so that the glass does not shatter and fall to pieces in case of an explosion or breakage.
- II.5.14. The worktop must be made of 10 mm thick high-quality stress relieved perforated polypropylene sheets. A skirting of 10 mm height and 25 mm width must be provided to prevent any spillage of chemicals on the floor.
- II.5.15. The worktop of the clean bench must house one overflow type DI water bath with dimensions of 200 mm x 200 mm x 300 mm (length x width x depth). The overflow type de-ionized (DI) water bath should be made of stress relieved high quality polypropylene and should be fully integrated into the clean bench. The top of the bath should be lower than the work top by at least 2 inches. The bath must be provided with a lid made of high-quality polypropylene so that it can be closed when not in use.
- II.5.16. When in use, DI water must continuously flow into the DI water bath and overflow out of the tank near the top of the bath. The overflow water must be collected and discharged through a drainpipe, preferably at a user settable flow rate between 1 *lpm* to 5 *lpm*. A shut-off valve must be provided to close the DI water supply when the bath is not in use. The bath must also be provided with an outlet near the bottom with a shut-off valve for draining the bath for routine cleaning. Both shut-off valves must be electronically controllable, ideally through a touch panel system that also shows the water resistivity and flow rate. The DI water bath is to be connected to the DI water supply system specified in section II.7.
- II.5.17. A main shut-off for DI water supply line and shut-off valves near the clean bench must be provided to shut-off DI water supply if required.
- II.5.18. Lighting with UV-filtering (to filter light with wavelength of <500 nm; specification sheets/data sheets for the UV filters must be provided) for an illumination level of 1000 lux or greater at worktop level on all points of the worktops, in the fume hood and the clean bench sections, should be provided.
- II.5.19. Magnehelic gauge of 50 mm of water column capacity to measure the differential pressure at the exhaust plenum box in fume hood portion of the workstation must be provided.
- II.5.20. Magnehelic gauge of 50 mm water column capacity to measure differential pressure inside work area of clean bench portion of the workstation must be provided.
- II.5.21. Three storage cabinet trolleys of 600 mm length each for chemicals/materials storage below the worktop. The trolleys must be made of high-quality polypropylene consistent with the specification in 1.5. One trolley under the fume

hood (Part-1) and two trolleys under the clean bench (Part-2) parts of WCS-1 are required.

II.6. Specifications for wet chemical station-2 for substrate processing using solvents

- II.6.1. The wet chemical station-2 (WCS-2) is a recirculating type ductless fumehood. Air from the cleanroom is drawn through the front over the work area and passed through suitable activated charcoal and HEPA particulate filters to remove any solvent vapors/particulates before discharging the air back into the cleanroom. The blower used must have sufficient capacity to maintain standard airflow rates. The internal airflow rates must be user controllable and a display must indicate the measured airflow speed. Lighting switches, air flow indicator and airflow controls must be provided on a control panel. *Details of filter specifications and maintenance schedule should be clearly given along with the technical bid.*
- II.6.2. WCS-2 overall dimensions should be 1800 mm x 900 mm x 2400 mm (width x depth x height).
- II.6.3. WCS-2 must be constructed out of stress relieved high-quality polypropylene sheets of thickness 10 mm or thicker (data regarding residual stress must be provided). Any material being quoted must meet all clean room material specifications as noted in I.5. In addition, the material should be compatible with a variety of clean room solvents and photoresist/developer solutions used in a clean room. ***A list of compatible solvents must be given.***
- II.6.4. A clear, transparent height adjustable counter-weight balanced sash made of solvent resistant material that is at least 6 mm in thickness should be provided. If this is a glass sash, it should be made of toughened laminated glass so that the glass does not shatter and fall to pieces in case of an explosion or breakage. The sash material should be compatible with all clean room solvents similar to the requirements in II.6.2.
- II.6.5. The worktop must be made of 10 mm or thicker perforated high-quality polypropylene sheet. A skirting that is 10 mm high and 25 mm wide must be provided at the front of the worktop to contain any spills on the worktop and prevent spilling on the floor. The worktop must be at a standard workable height from the cleanroom floor. The worktop height being provided must be given with the technical bid.
- II.6.6. One Nitrogen gun made of virgin PTFE with anti-static protection must be provided. The nitrogen blow gun should be centrally located so that it can be used throughout the working space of the solvent bench. The piping for the nitrogen gun must be flexible, resistant to common clean room solvents and not outgas or generate particulates (provide specifications or manufacturer data sheet). The piping must have sufficient length to reach all portions of the work top. When not in use, the extra piping must retract and be concealed inside the centrally located space between the fume hood and the clean bench.
- II.6.7. Gas supply line for nitrogen from gas connection points, which are **3 meters** from the solvent workstation, should be included in the scope of work. These gas lines must be constructed from high-quality SS316L grade stainless steel tubing.
- II.6.8. An in-line gas regulator rated to take an inlet pressure of 15 bar or higher and rated to provide an outlet pressure between 0-15 bar with outlet pressure indication, and a diaphragm type shut-off valve must be provided at an accessible

location near the workstation. The pressure regulator should be SS316 barstock type construction with SS316L diaphragm. All fittings must be suitable for gas pressure control of noncorrosive high purity gases up to grade 5.0 purity (99.999%).

- II.6.9. Lighting with UV-filtering (should filter out light with wavelengths of <500 nm; specification sheets/data sheets for the UV filters must be provided) for an illumination level of greater than 1000 lux at worktop level on all points of worktop inside the workstation should be provided.
- II.6.10. Magnehelic gauge of 50 mm of water column capacity to measure the differential pressure inside the working area of the workstation must be provided.
- II.6.11. At least two storage cabinets of at least 600 mm length each for chemicals/materials storage under the work top must be provided. At least one of the storage cabinets must be a 30-minute fire rated flammable materials storage cabinet rated to contain any fires for at least 30 minutes.
- II.6.12. A separate common polypropylene sink of size 450 x 400 mm with a drying area must be provided. It must have a polypropylene gooseneck with a tap and connected to the DI water supply line. The drain of the sink must be piped into the building drainage duct.

II.7. Specifications for deionized water system

- II.7.1. A de-ionized water system consisting of a generation and storage system for generating and storing Type-I (resistivity $\geq 18 \text{ M}\Omega\text{-cm}$) and Type-II water (resistivity $\geq 1 \text{ M}\Omega\text{-cm}$) should be provided. In addition to the resistivity metrics, the DI water system should comply with all Class-1000 clean room specifications. The vendor must design the system to meet all specifications and share the plant design and associated calculations. The vendor should also attach relevant specification sheets along with the technical bid.
- II.7.2. The DI water plant must be designed to support usage of upto 300 liters/day of Type-II water and upto 100 liters/day of Type-I water with peak usage of 10liters/minute for Type-I water and 10liters/minute for Type-II water (this does not include the usage by the Type-I water generator). The Type-II water generated is to be stored in a storage tank of suitable capacity. The water tank should be made of clean room grade polypropylene. The system must be equipped with an automatic cut-off to stop water generation once the storage tank is full. The Type-II water is to be used as feed water for the Type-I water system.
- II.7.3. The DI water plant along with the storage tank is to be installed in the utility area behind the lab space housing the cleanroom. The plumbing of Type-I water and Type-II water system to the respective distribution lines inside the cleanroom is to be included in the scope of the work. The piping set required to cover a distance of 10 meters between the DI generator and the POU (II.5 and II.6) inside the cleanroom is included in the scope of this work. As an option, the vendor may specify the cost of installing additional piping (if estimated to be greater than 10 m) on a per foot basis.
- II.7.4. The Type-II water distribution system is to be connected to the POU - DI water bath in wet chemical station-2 (section II.6) and must provide water at the specified flow rate. Type-I water distribution system is to be connected to POU spray gun installed in wet chemical station-1 (section II.5) and must provide water at 10 litres per minute at an output pressure of 1 bar at the spray gun outlet.
- II.7.5. The Type-I water system must continuously recirculate the water to provide constant fluid flow and eliminate dead legs to POU.
- II.7.6. Water quality monitors must be provided for live monitoring of the Type-I and Type-II water quality from the system. Resistivity sensors and display of measured resistivity value must be included.
- II.7.7. The feed water is municipal supply water/borewell water or a mixture of the two. The feed water quality and pressure may vary. The vendor must provide appropriate pre-treatment/filter systems.
- II.7.8. Wastewater, if any, from the Type-I and Type-II systems should be connected to the building drain.
- II.7.9. The vendor must label all water supply lines with fade-proof easily readable labels at appropriate locations and must provide drawings and documentation of the final water plumbing layout.
- II.7.10. All electrical wiring and power points required for powering the DI plant is to be included in the scope of this work and must be done according to standards specified in section II.2.

III. Specifications and Requirements for the Class-10000 Clean Room Section

III.1 Layout and Construction

- III.1.1. **Floor plan:** Floor Area: ~47sq. m. Refer appendix for floor plan (Section VI.2).
- III.1.2. **Wall panels:** The wall panelling must be modular, interlocking type and double skinned with both sides being powder coated GI (class-10000 clean room grade) with a skin thickness of at least 0.8 mm with a powder coating thickness of 60 microns or greater. Wall panels with built-in air raisers for extracting return air from the cleanroom are preferable. Such panels must be at least 100 mm in thickness with polyurethane foam (PUF) infilling with a density greater than or equal to 40 kg/m³. The panels must be reinforced along the periphery. Panels must be mounted and secured on suitable tracks. All joints must be sealed with cleanroom compatible neutral grade silicone sealant. All cut-outs must be covered with a suitable track. If wall panel design other than those with built-in air risers are provided, suitable technical or economy of cost justification must be given. In such alternate designs, skin thickness must be at least 0.8 mm and the powder coating thickness should be 60 microns or greater, and the panel thickness must be 50 mm or greater. The material of the panels must be clean-room compatible powder coated GI.
- III.1.3. **Ceiling:** The cleanroom ceiling must be at a height of 2500 mm or higher from the floor of the cleanroom. The ceiling height of the lab space housing the Class-10000 cleanroom is ~5250 mm. The ceiling panelling must be modular, and double skinned with both sides being powder coated GI (clean room grade) with a skin thickness of at least 0.8 mm and powder coating thickness of at least 60 microns. The panels must be at least 50 mm thick with PUF infilling with a density greater than or equal to 40 kg/m³. The panels must be reinforced along the periphery and mounted on suitable tracks. All joints must be sealed with cleanroom compatible neutral grade silicone sealant. All cut-outs must be covered with a suitable track.
- III.1.4. **Flooring:** The flooring must be anti-skid, hard wearing and electrostatic dissipative and sufficiently thick and dense to bear the weight of equipment. ESD specifications should meet criteria given in I.6. Each tile must be at least 12" X 12" in area, have a ESD material thickness of at least 3 mm. Vinyl as an ESD material is preferred.
- III.1.5. **Covings:** Cleanroom compatible Aluminum covings must be installed at corner joints of (a) Wall – Wall (b) Wall – Ceiling (c) Wall – Floor. All 3D corners must be installed and must be covered by 3D pieces. All covings must have sufficient conductivity to enable dissipation of any electrostatic charge built-up and enable the total resistance to be in the range given in I.6. Other materials such as PVC will be acceptable with suitable justification.
- III.1.6. **Doors:** (i) Double shutter door spanning a width of 1.7 m (each door 0.85 m wide) and 2.1 m height (marked D1 in VI.2) and (ii) One double shutter door spanning 1.1 m (each door 0.55 m wide) and 2.1 m height (marked D2 in VI.2). The doors must be double skinned with both sides being powder coated GI (class-10000 clean room grade) with a skin thickness of at least 0.8 mm and powder coating thickness of at least 60 microns. The doors must be at least 44mm in thickness with PUF infill (density > 40kg/m³). The doors must be flush with the panels

when closed and must be fixed to the door frames with concealed stainless-steel double bearing butt-hinges as per BS7352 specification. The doors must be provided with all ancillaries like door closer, lock and key, D-handle, push plate, tower bolt all made of SS. Door D1 must be provided with a view glass of size 0.4m x 0.4m. All doors must open to the outside of the cleanroom and must be provided with a panic bar so that the doors be can quickly opened to exit the cleanroom in the case of an emergency. One leaf of door D1 is to kept closed during normal operations. The other leaf of D1 is meant for personnel access to the cleanroom and is to have an access control system. D2 is meant to be used as an emergency exit. All doors should have concealed type automatic door bottom seals.

- III.1.7. **Access control:** A biometric-based access system should be included. This should be configurable for multiple users. This should be interlocked with an emergency alarm located outside the clean room. The cost for the installation of the emergency alarm is to be quoted.
- III.1.8. **Air curtains:** Air curtains must be provided near the door D1 for preventing entry of particles from outside the cleanroom and must automatically turn on when a user enters the cleanroom.
- III.1.9. One safety eye shower must be provided inside the cleanroom at a suitable location.

III.2. *Lighting and Electrical installations for Class-10000 cleanroom section*

- III.2.1. Sufficient ultra-violet-filtered, ceiling mounted LED lighting must be provided through-out the cleanroom. **All radiation below 500 nm must be blocked by the UV filters in the lighting systems** (specification sheets/data sheets for the UV filters must be provided). The lighting must be sufficient to provide 400 lux or greater illumination at 1 m from the cleanroom floor at all points inside the cleanroom. The illumination intensity must be demonstrated before commissioning. The lighting controls must be provided at user accessible locations inside the cleanroom near the user access door. The necessary fittings, wiring from distribution board and switches must also be supplied and installed.
- III.2.2. 40 numbers 5/15A single-phase power points, 2 numbers 3-phase, 32A power points. These power points must be distributed over 5 lines each equipped with a suitable rated terminal circuit breaker (MCBs). Each of the power point must be labelled to indicate the line it is connected to. The MCBs are to be housed in a separate power distribution board inside the cleanroom. The distribution board must be constructed out of cleanroom compatible materials.
- III.2.3. All motors and switchgears required for various items shall generally be all electric. Motors shall be suitable for 3 Phase, 50 Hz, 415 volts A.C. supply. The AC supply variability could be between +/- 10%. Therefore, the motors should withstand such load fluctuations. If the motor input is not suitable for power fluctuations, a voltage stabilizer should be provided. Electrical supply from electrical panel to respective AHUs/Condensing Units/Dehumidifier must use armoured cables. Any underground cabling must be steel armoured.
- III.2.4. All electrical wiring/cabling must be fire retardant and of a reputed make and must be sufficiently rated to handle the specified loads. The wiring/cabling must be routed through fire-retardant electrical conduits. Inside the clean room, the cables must be routed through appropriately sized fire-retardant PVC dado with partitions for routing cables and positioning power points separately.

- III.2.5. A suitably rated electrical panel must be provided and cables from AHU and other electrical units must be terminated at the panel. Copper lugs should be insulated for cable termination. All bus bars in the panel should be of copper. Incoming cabling termination at the electrical panel will be provided by IISc.
- III.2.6. All wires/cables must be color coded according to applicable electrical wiring standards. The wires must be labelled appropriately at the terminals. All electrical wiring diagrams/drawings with corresponding labels must be provided with installation documents.

III.3. Installation of gas lines and accessories for Class-10000 cleanroom

- III.3.1. Gas distribution lines, one each for ultra-high purity Nitrogen, ultra-high purity Argon and ultra-high purity 5-10 % Hydrogen-in-Argon gas mixture must be installed. ***Each gas line must be plumbed from a gas storage bay outside the cleanroom and terminated at a gas manifold inside the cleanroom with at least 3 output lines. Each output line at the manifold must have a diaphragm type shut off valve. The cost of fittings and piping for 5 meters per distribution line is in the scope of work (3 gas distribution lines with 5 meters per line).*** As an option, the vendor must quote the cost for laying any additional length of gas lines on a per foot basis.
- III.3.2. The vendor must quote for supply and installation of components for connecting the gas lines to gas cylinders described as follows: Each gas line must have a flexible high-pressure SS hose (SS316L core and SS wire braided outer layer) 1 meter in length connected with a ***bull nose*** appropriate for each gas mentioned in section III.3.1 (the bull nose should not have an O-ring seal). The bull nose must be connected to the hose through a ***non-return valve***. The SS hose must be connected to a gas pressure regulator through a diaphragm type ***shut-off valve***. The regulator must be of all stainless-steel construction capable of handling inlet pressure of 200 bar. Outlet pressure must be adjustable over 0-15 bar. A sample configuration is shown in figure 2. The regulator must be of barstock type with ***SS316L diaphragm*** from a reputed OEM. *All sealing materials used inside the regulators/shut-off valves must be cleanroom compatible and must also be compatible with the particular gas type and purity grades.* The vendor must attach datasheets/specifications for the same. Gas regulators and other components should be provided from the list of preferred OEMs, where provided.
- III.3.3. The plumbing of (i) UHP-Argon and (ii) 5-10 % Hydrogen-in-Argon gas mixture lines from the gas manifold up to the inlets of a glovebox housed inside the clean room to must be quoted. 10 meters of gas tubing must be quoted for each gas line. Any additional gas tubing must be quoted on a per foot basis, as an option.
- III.3.4. Gas tubing must be supported on channel mounted tubing support with provision to carry a total of 5 lines.
- III.3.5. Any unconnected lines must be appropriately terminated with suitable fittings.
- III.3.6. All support structures and fittings inside the cleanroom must be resistant to acids and common organic solvents.
- III.3.7. All gas lines and accessories must be constructed out of high quality SS316L and must be of a reputed make. Compression type seals are acceptable, if compatible with clean room specifications. The RMS roughness of the inner body of the SS tubing must be 10Ra or better.
- III.3.8. All gas lines must be leak-checked after installation.

- III.3.9. All gas lines must be labelled at appropriate intervals with clearly visible fade-proof labels easily readable by the user. The vendor must also provide drawings of the final gas plumbing layout.

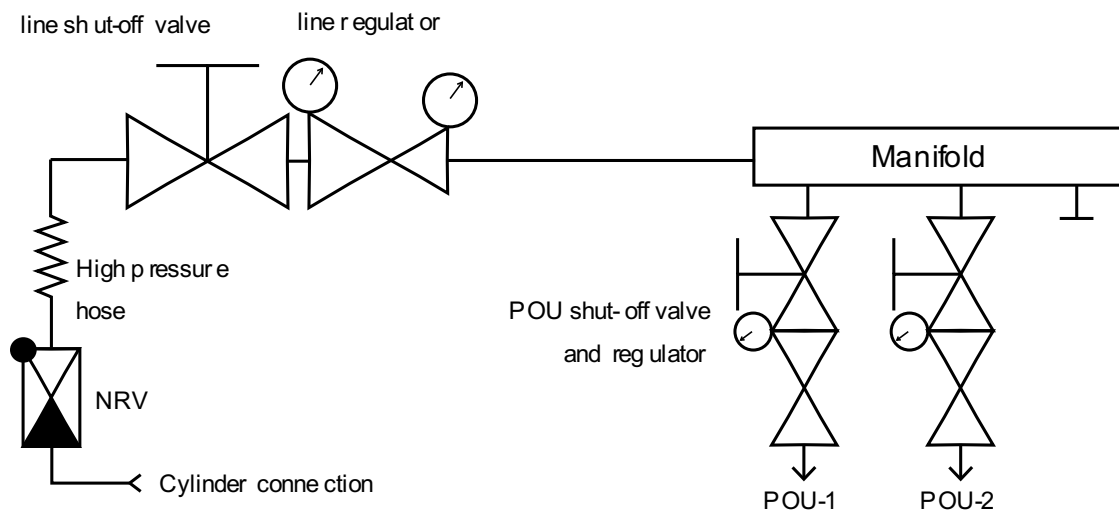

Figure 2: Sample gas line configuration

III.4. Air Handling Unit and related specifications for Class-1000 cleanroom section

- III.4.1. A dedicated recirculating type Air handling unit/HVAC system must be provided for the class-10000 cleanroom
- III.4.2. The HVAC system must be designed to maintain the class-10000 clean room conditions as specified below:
- 1) Air purity: Particulate concentration of less than 10000 particles per cubic feet (Class-10000) according to ISO 14644
 - 2) Room temperature of 22 ± 2 °C
 - 3) Relative humidity levels (RH) of $45 \pm 5\%$
 - 4) Differential pressure of 15-20 Pa
 - 5) Number of users: **five** users
 - 6) Estimated equipment load: 10 kW (duty factor = 50% i.e., assume that the space has to be designed for an average heat load of 5 kW).
 - 7) Air flow pattern: Mixed Flow
 - 8) Supply air Design: Negative pressure plenum type airflow using FFU with suitable HEPA filters or hooded HEPA filter-based design.
 - 9) Supply air change rate: 60 air changes per hour
 - 10) Supply air velocity: minimum 90 fpm $\pm 20\%$ (0.45 mps $\pm 20\%$)
 - 11) Filter coverage: minimum 15%
 - 12) Fresh air changes per hour: 3
- III.4.3. The Air Handling Units (AHU) must be designed to meet specifications in III.4.1 and III.4.2. Fresh air intake must also take into account the exhaust of the fume hood specified in section III.5. The AHU must be fitted with appropriate cooling coils, humidifiers, dehumidifiers, pre-filters etc. required to maintain the air temperature and humidity within specification III.4.2. The condenser unit must have a capacity of 5 TR or greater. The air heater module must also be appropriately rated. Only non-toxic, environment friendly refrigerants (R-407C

or equivalent) may be used in the condenser units. Details of the refrigerant must be provided. All refrigerant piping and connectors must be made of copper and suitably insulated.

- III.4.4. Treated fresh air needs to be provided in order to compensate for any losses and also to maintain spatial positive pressure in the cleanroom. Precooling coils with suitable pre filters, volume control dampers (VCDs), mixing box, heaters, mist eliminators etc. shall be provided for the fresh air intake of the AHU.
- III.4.5. AHU must be installed on the roof of the building that houses the clean room. Approximate length of the ducting required is 14 meters. The vendor may specify optional per meter cost for any extra ducting work.
- III.4.6. Clean air entry into the clean room portion may be either through hooded HEPA filters (hermetically sealed designs) or Fan Filter Units suitably located in a negative pressurized plenum. The standard operating cost of the design should be provided. Economical designs that decrease capital and operating costs will be given preference. Clear justifications showing the suitability of the adopted design is required. An air flow diagram must be provided with the technical bid.
- III.4.7. The filters in either of the units of III.4.6 should be modular in design and must be sourced from a reputed Original Equipment Manufacturer (OEM). Sufficient number of these units must be provided to maintain the cleanroom particulate and other specifications (specification III.4.2).
- III.4.8. All units must have HEPA filters manufactured by a reputed OEM. The filters must remove particulates bigger than 0.3 micron with 99.997% or greater efficiency (vendor must provide manufacturer specifications or supporting data). The quote must include details of the OEM. The units must also be equipped with prefilters to remove particulates bigger than 10 microns with 90% or greater efficiency.
- III.4.9. All unit enclosures must have a double skinned corrosion resistant enclosure with a thermal and acoustic insulating infill i.e. PUF of sufficient density ($> 40\text{kg/m}^3$). The enclosure must be provided with fire and smoke detectors and alarms, inspection doors and necessary inspection lighting. All mounts and frames for the indoor/outdoor units must be painted, be corrosion resistant and must be suitably padded to minimize vibration and noise.
- III.4.10. All ducting must be fabricated according to the latest SMACNA standards and must be compatible for the cleanroom classification. The air handling ducts and ducting joints must be made of corrosion resistant material that is resistant to any acid vapors and must have a minimum thickness of 24 gauge ($\sim 0.635\text{mm}$) conforming to the latest SMACNA and cleanroom standards. The clause regarding acid resistance may be relaxed for portions, that the vendor has sufficient reason to believe, would never be exposed to acid vapors. However, the vendor must provide suitable drawings/documentation to support this. The ducting must be low noise and vibration free. All ducting/joints must be tested for leakage before commissioning and the leakage must be within the limits specified in the latest SMACNA standards.
- III.4.11. All ducting must be provided with sufficient thickness of insulation. The insulation must be fire retardant and aluminum faced. Provision must be made for internal cleaning of the ducting at appropriate locations.
- III.4.12. Any grills/diffusers used must be made of extruded anodized aluminum.
- III.4.13. All clamps/fastenings used for the ducting must be corrosion resistant.

- III.4.14. Alarms indicating any faults including fire and smoke alarms and alarms for detecting faults in the air handling system must be installed inside the cleanroom to alert users inside the cleanroom in case of any emergencies.
- III.4.15. An indicator/display unit for clean room temperature, RH and air handling system status along with a gauge showing the differential pressure of the cleanroom must be provided inside the cleanroom.

III.5. Specifications for fumehood

- III.5.1. The fumehood is meant for wet chemical processing using organic solvents and de-ionized water and must be provided with an exhaust system.
- III.5.2. The overall dimensions of the fumehood are *1800x800x2400 mm (width x depth x height)*.
- III.5.3. The fumehood must be constructed out of stress relieved high-quality polypropylene sheets of thickness 10mm (data regarding residual stress in the sheets must be provided). Any material being quoted must meet all clean room materials specifications as noted in I.5. In addition, the material should be compatible with a variety of clean room solvents and photoresist/developer solutions used in a clean room. ***A list of compatible solvents must be given.***
- III.5.4. The fumehood must be provided with a flat worktop made of 10mm thick polypropylene sheet. A skirting of width 25 mm and 10 mm height must be provided at the front of the worktop to contain any spills on the worktop and prevent spilling on the floor. It must include a polypropylene sink as specified in section III.5.11. The worktop must be at standard fumehood worktop height from the cleanroom floor. The worktop height should be provided with the technical bid.
- III.5.5. A clear transparent height adjustable counter-weight balanced sash made of acid and solvent resistant material that is at least 6mm in thickness. If this is a glass sash, it should be made of toughened laminated glass so that the glass does not shatter and fall to pieces in case of an explosion or breakage.
- III.5.6. The fumehood must have a standard value for face opening at full sash position. The sash opening at full sash position must be provided with the technical bid
- III.5.7. At fumehood must have standard fumehood face opening at full sash position and must maintain a face velocity between ***90-110 fpm*** at half sash position. The fumehood exhaust blower must be suitable rated and all ducting must be fire-resistant polypropylene. Fire resistance rating should be clearly mentioned. The quote should include all necessary fittings for routing the exhaust duct and installation of the blower.
- III.5.8. Two Nitrogen guns made of virgin PTFE with anti-static protection must be provided at each end of the fumehood worktop. The nitrogen blow guns must have a filter housing with disposable filters. The piping for each of the guns must have enough length to reach the whole of the work area. When not extended, the extra piping must retract and be concealed inside the workstation body. The piping must be resistant to acids and common solvents and must not outgas or generate particulates (provide specifications/manufacturer data sheets with quote)
- III.5.9. One Gas supply line for nitrogen from gas connection points, which are **3 meters** from the fume hood, should be included in the scope of work. These gas lines must be constructed from high-quality SS316L grade stainless steel tubing.

- III.5.10. A gas line regulator rated at 0-15 bar with line and outlet pressure indication and a diaphragm-type shut-off valve must be provided on the gas supply line to the control the pressure of the nitrogen at an accessible location near the workstation. The pressure regulators must be SS316L barstock type construction with SS316L diaphragm. All fittings must for suitable for pressure gas control of noncorrosive, high purity gases up to grade 5.0 purity (99.999%).
- III.5.11. A polypropylene sink with 250 x 200 mm must be provided inside the fumehood at back left corner. It must have a polypropylene gooseneck with a tap and connected to the DI water supply line. The drain of the sink must be piped into the building drainage duct.
- III.5.12. Lighting with UV-filtering to filter light with wavelength of <500 nm (specifications or manufacturer data sheets must be provided) for an illumination level of 1000 lux or greater at worktop level on all points of the worktops, in the fume hood and the clean bench sections, should be provided.
- III.5.13. Magnehelic gauge of 50mm of water column capacity to measure the differential pressure at the exhaust plenum box in part-1 (fume hood) of the workstation must be provided.
- III.5.14. Two storage cabinet trolleys of 900mm length each for chemicals/materials storage under fumehood. The trolleys must be made of high-quality polypropylene.

IV. List of approved manufacturers

Any one of the following makes of equipment/components/items are acceptable to the company subject to meeting the technical specifications specified in the tender. Please note that any other makes which are specified as EQUIVALENT may be accepted, provided the vendor furnishes appropriate technical justification comparing their technical equivalency. The vendor should also provide detailed technical specifications of the product if not quoted from the approved list. Such technical specifications should also be verifiable such as the availability of technical specifications on the OEMs website or OEMs technical documents. IISc may ask the vendor to submit a sample, where applicable. The approval of makes not listed here will depend on the technical information provided/available and will be at the discretion of the purchase committee.

IV.1. Cleanroom construction

Description of items	Approved makes
Air Curtain for class-10000 clean room entrance	ALMONARD/ FABTECH/ I-CLEAN
Wall panels, Ceiling panels and mounting systems	PLASCORE / CHANNEL SYSTEMS/ VEROVERIA/ RITTERWAND/ FLEXICON/ AMERICAN CLEANROOM SYSTEMS
UV filter films for door vision panels and windows	UV PROCESS SUPPLY USA/ DURXTREME GMBH/ ASMETEC GMBH
Antistatic vinyl flooring tiles	FORBO/ STATCLEAN/ TARKETT/ WONDERFLOOR/ GERFLOR/ DOY YEE
RH and temperature indicator	WAREE/ HTA
Magnahelic gauge	WAREE/ DWYER/ SENSOCON
Emergency eye wash	KLENZAIDES/ I-CLEAN/ GMP/ CRP/ FABTECH

IV.2. Air handling systems

Description of items	Approved makes
Air Handling Units	EDGETECH/ ZECO/ SYSTEMAIR/ FLAKTWOOD/ CITIZEN/ I-CLEAN
AHU Fan blower	NICOTRA/ KRUGER/ FLAKTWOODS
Motors for AHU	CROMPTON GREAVES/ ABB/ SIEMENS /KIRLOSKAR (motors shall be the highest star rated category as per bee)
Motor Soft starter	SIEMENS/ ABB/ L&T/ SCHNEIDER

Fan Filter Units/HEPA filters for Class-1000 and Class-10000	CAMFIL/ AAF/ CFS/ FREUDENBERG/ EGCLEANTECH/ UNIFIL
Chiller unit	YORK/ CARRIER / TRANE/ CLIMAVENTA
Chiller Motors	ABB/ SIEMENS/ CROMPTON GREAVES
Chilled / Condenser Water Pipes	SAIL/ TATA/ JINDAL
Globe Valve/ Gate Valve/ Check valve	CASTLE/ ADVANCE/ AUDCO/ ALFA LAVAL/ LEADER
Butterfly Valve	AUDCO / L&T/ KIRLOSKAR/ ADVANCE/ BELIMO/ CASTLE
3 Way Control/ Mixing Valve	HONEYWELL/ SIEMENS/ BELIMO
Balancing Valves/ Flow Measuring devices	BELL & GOSSETT/ TOUR & ANDERSON/ ANERGY/ SIEMENS/ ADVANCE
Water flow Switch	HONEYWELL/ SIEMENS/ BELIMO
Ducting – GI sheets	SAIL / JINDAL / TATA
Flexible duct	ATCO/ GP SPIRO/ ROLASTAR
Duct Insulation	ARMAFLEX/ K- FLEX/ SUPREME/ TROCELLENE/ ARMACELL
Magnehelic gauges	WAREE/ DWYER/ SENSOCON
Damper Actuators	HONEYWELL/ SIEMENS/ BELIMO
Grilles/ Diffusers/ VCD/ Ducting fittings	AIR MASTER/ CARYAIRE/ AJANTA/ SYSTEM AIR / FLAKTWOOD/ COSMOS/ RUSKIN TITUS
Temperature/ RH/ Pressure Sensors (Cleanroom)	HONEYWELL/ SIEMENS/ JOHNSON
Pressure gauges	WIKA/ FORBES MARSHALL
RH and temperature indicator	WAREE/ HTA
Thermostats/ Humidistat	SAUTER/ SIEMENS/ JOHNSONS/ HONEYWELL
Dehumidifiers	BRY-AIR/ MUNTERS/ WHITE WASHINGHOUSE/ APPIDI/ AIR PACK
Pan type humidifier	RAPID COOL/ NORDAMANN/ WALTER MEIER/ APPIDI/KEPL
Electrical Strip Heaters	HEATCON/ DASPASS/ ESCORTS/RAPID COOL/KEPL

Electrical LT Panels as per IEC 61439-1	LEGRAND/ SCHNEIDER ELECTRIC / SIEMENS / ABB /L&T or their authorized franchisees/ system integrators
MCCB	SIEMENS/ SCHNEIDER/ ABB / L&T / LEGRAND
MCB	SIEMENS/ SCHNEIDER/ ABB / L&T / CG / HAGER / INDO ASIAN
Power/ Control Contacts, Overload Relays, Timers, etc.	SIEMENS/ SCHNEIDER/ ABB / L&T
Fuses	SIEMENS/ SCHNEIDER/ ABB / L&T
Power Cables/ Control Cables/ Wires	FINOLEX/ UNIVERSAL/ POLYCAB/ UNISTAR/ NICCO / RAVIN

IV.3. Fumehood/ Wet chemical station

Description of items	Approved makes
Blower motors for fumehood, ductless fumehood, cleanbench etc.	CROMPTON GREAVES/ ABB/ SIEMENS /KIRLOSKAR (Motors shall be the highest star rated category as per BEE)
Fan Filter Units/HEPA filters for Class 100 clean benches	CAMFIL/ AAF/ CFS/ FREUDENBERG/ EGCLEANTECH/ UNIFIL
Magnehelic gauges	WAREE/ DWYER/ SENSOCON
Gas pressure regulator	SWAGELOK/ GCE/ SANDVIK/ VALEX/ DOCKWEILER
Gas Piping and fittings	SWAGELOK/ GCE/ SANDVIK/ VALEX/ DOCKWEILER

IV.4. Gas piping

Description of items	Approved makes
SS tubing	SWAGELOK/ GCE/ SANDVIK/ VALEX/ DOCKWEILER
Regulators	SWAGELOK/ MATHESON/ GCE/ HALEHAMILTON/ MESSER
Valves	SWAGELOK/ MATHESON/ GCE/ VALEX, TK-FUJIKIN/ DOCKWEILER
Fittings, flexible high-pressure hoses, tubing mounts etc.	SWAGELOK, MATHESON, GCE, DOCKWEILER

IV.5. Lighting and electrical

Description of items	Approved makes
Lighting – LED	PHILIPS /OSRAM
Electrical LT Panels as per IEC 61439-1	LEGRAND/ SCHNEIDER ELECTRIC / SIEMENS / ABB /L&T OR THEIR AUTHORIZED FRANCHISEES/ SYSTEM INTEGRATORS
MCB distribution boards	LEGRAND, SIEMENS, CROMPTON, HAVELLS
LT cables	NICCO/UNIVERSAL/ FINOLEX
Power Cables/ Control Cables/ Wires	FINOLEX/ UNIVERSAL/ POLYCAB/ UNISTAR/ NICCO / RAVIN
Electrical conduits	POLYCAB/ AVONPLAST / SUDHAKAR/ PRECISION/AKG
Switches/Sockets	ANCHOR/ MK/ LEGRAND/ ABB/CRAB TREE/ SCHNEIDER ELECTRIC
MCBs	SIEMENS/ SCHNEIDER/ ABB / L&T / CG / HAGER / INDO ASIAN
MCCB	SIEMENS/ SCHNEIDER/ ABB / L&T / LEGRAND

IV.6. De-ionized water system

Description of items	Approved makes
DI water system	EVOQUA WATER TECHNOLOGIES/ MILLIPORE /KOMAL / GRAUER &WEIL, / PURELAB-ELGA /

IV.7. Safety and access control

Description of items	Approved makes
Fire/smoke detection and alarm systems	NOTIFIER / SIEMENS / GE / APOLLO (UL CERTIFIED ONLY)
Safety Eye Shower	PAL BAM / TERRA UNIVERSAL /NUAIRE/ CLEAN ZONES /ROTH
Access control and emergency systems	SIEMENS / BOSCH / HONEYWELL

V. Terms and conditions

- V.1. The vendor is responsible for the design, supply, commissioning and validation of the cleanrooms and all utilities/equipment covered under the contract.
- V.2. The electrical system installation shall be carried out by qualified electricians either employed or contracted by the vendor.
- V.3. The vendor must arrange for materials unloading and staging.
- V.4. The vendor must demonstrate that the performance and quality parameters of the cleanroom and equipment comply to the specifications. Following performance tests must be carried out at three occupancy states: as-built, at-rest, and operational.
 - a) Air-borne particle count for ultrafine particles
 - b) Airborne particle count for macro-particles
 - c) Airflow test, air velocity measurement, leakage test, room pressurization test
 - d) Air pressure difference test
 - e) Temperature test
 - f) Humidity test
 - g) Illumination level measurement according to DIN 5035
 - h) Recovery test
- V.5. The vendor shall supply cleanroom certifications complying with ISO 14644 requirements.
- V.6. The price quotation should include the cost of installation, validation and training of potential users (about 5 users per clean room).
- V.7. The system should be provided with at least **3-years of warranty**, on all parts and labor, from the date of installation.
- V.8. The vendor must provide routine maintenance of the cleanroom and associated equipment that is part of this tender.
- V.9. The vendor should have a track record of having previously supplied and installed at least five cleanroom systems in India with similar specifications. Details of such systems should be provided.
- V.10. The vendor should have qualified technical service personnel for the equipment based in India and should assure a response time of less than 48 hours.
- V.11. Vendor must provide a user list (with contact details including emails and phone numbers) of at least 5 customers from Indian Institutes/Labs where similar systems have been installed.
- V.12. The lead-time for the delivery of the equipment should not be more than 6 months from the date of receipt of our purchase order.
- V.13. The indenter reserves the right to withhold placement of final order. The right to reject all or any of the quotations and to split up the requirements or relax any or all of the above conditions without assigning any reason is reserved.
- V.14. Wherever requested data must be supplied along with technical compliance documents. Technical bids without supporting data will be deemed as technically non-compliant.
- V.15. All guaranteed specifications will have to be demonstrated at the time of installation. Any necessary standard samples for that purpose should be brought by the service engineers.
- V.16. Printed literature and published papers in support of all compliance to the prescribed specifications may be provided.

- V.17. The vendor **must provide compliance statement** in a tabular form with respect to each technical specification in the tender document duly supported by the manufacturer's literature and published papers. Any other claim will not be accepted and may lead to rejection of the bid.
- V.18. Technical evaluation by the institute may include demonstration to verify functionalities and capabilities of the system quoted. Any discrepancy between the promised specifications and measurements will be deemed as technical non-compliance.
- V.19. The vendor must quote for a non-comprehensive AMC price beyond the 3-year warranty period, with a price lock in for 2 years beyond the standard 3-year warranty period. 2 services per year should be included in the AMC.
- V.20. The quote should also include additional spares sufficient for three years of system usage assuming an average usage of 120 hours of operation per week.
- V.21. The Bidder's firm should have existence for a minimum of 3 years. Enclose Company Registration Certificate and balance sheet of last three years.
- V.22. The Bidder should belong to either class 1 or class 2 supplier distinguished by their "local content" as defined by recent edits to GFR. They should mention clearly which class they belong to in the cover letter
- c) Class 1 supplier: Goods and services should have local content of equal to or more than 50%.
 - d) Class 2 supplier: Goods and services should have local content of equal to or more than 20 % and less than 50%.
- Purchase preference as defined by the recent edits to GFR (within the "margin of purchase preference") will be given to Class-1 supplier.
- V.23. The bidder should sign and submit the declaration for Acceptance of Terms and Conditions as per -Annexure 4.
- V.24. The Bidder must not be blacklisted/banned/suspended or have a record of any service-related dispute with any organization in India or elsewhere. A declaration to this effect has to be given as per Annexure 3.

VI. Appendix

VI.1. Class-1000 cleanroom floor plan

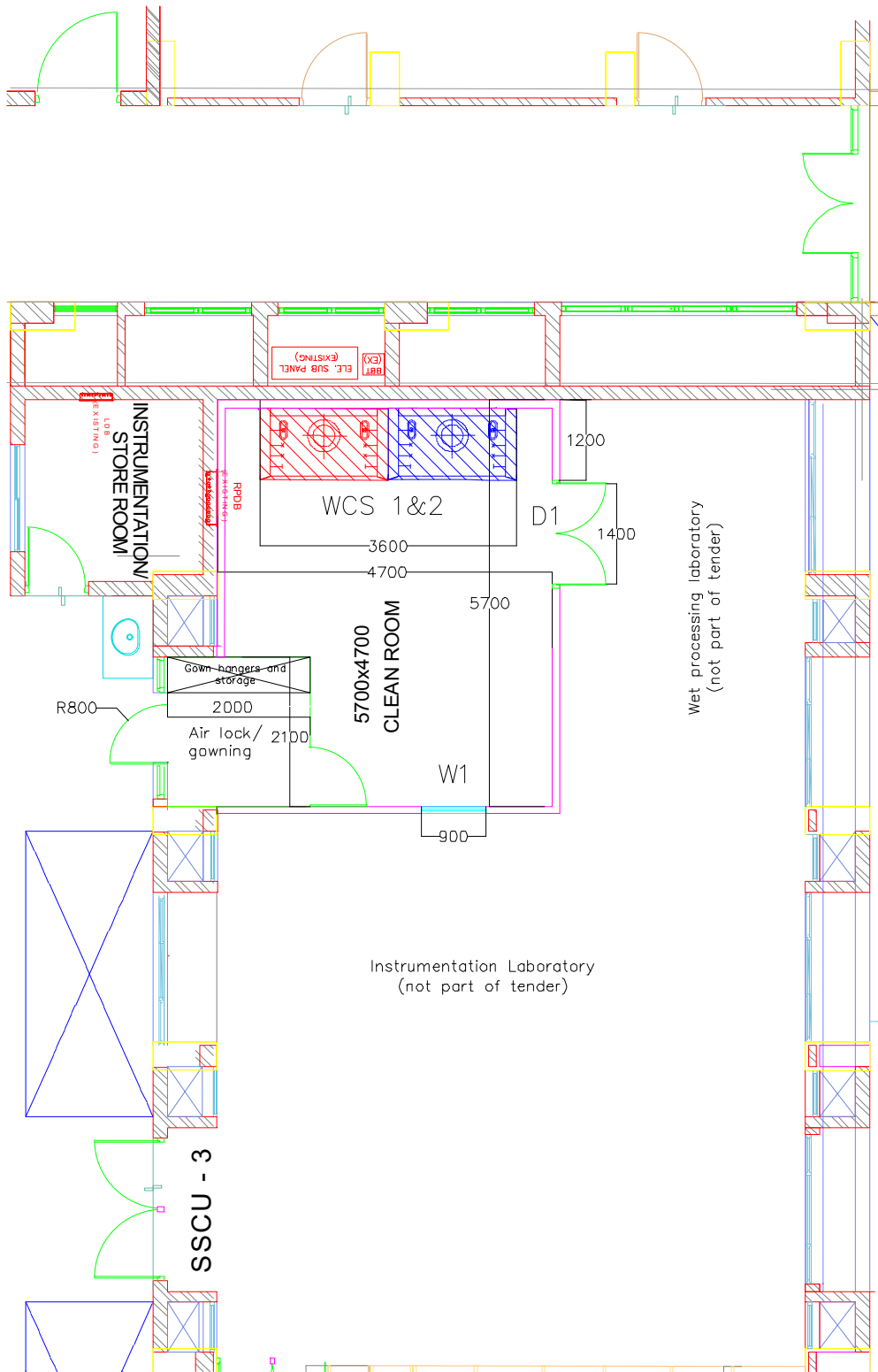

VI.2. Class-10000 cleanroom floorplan

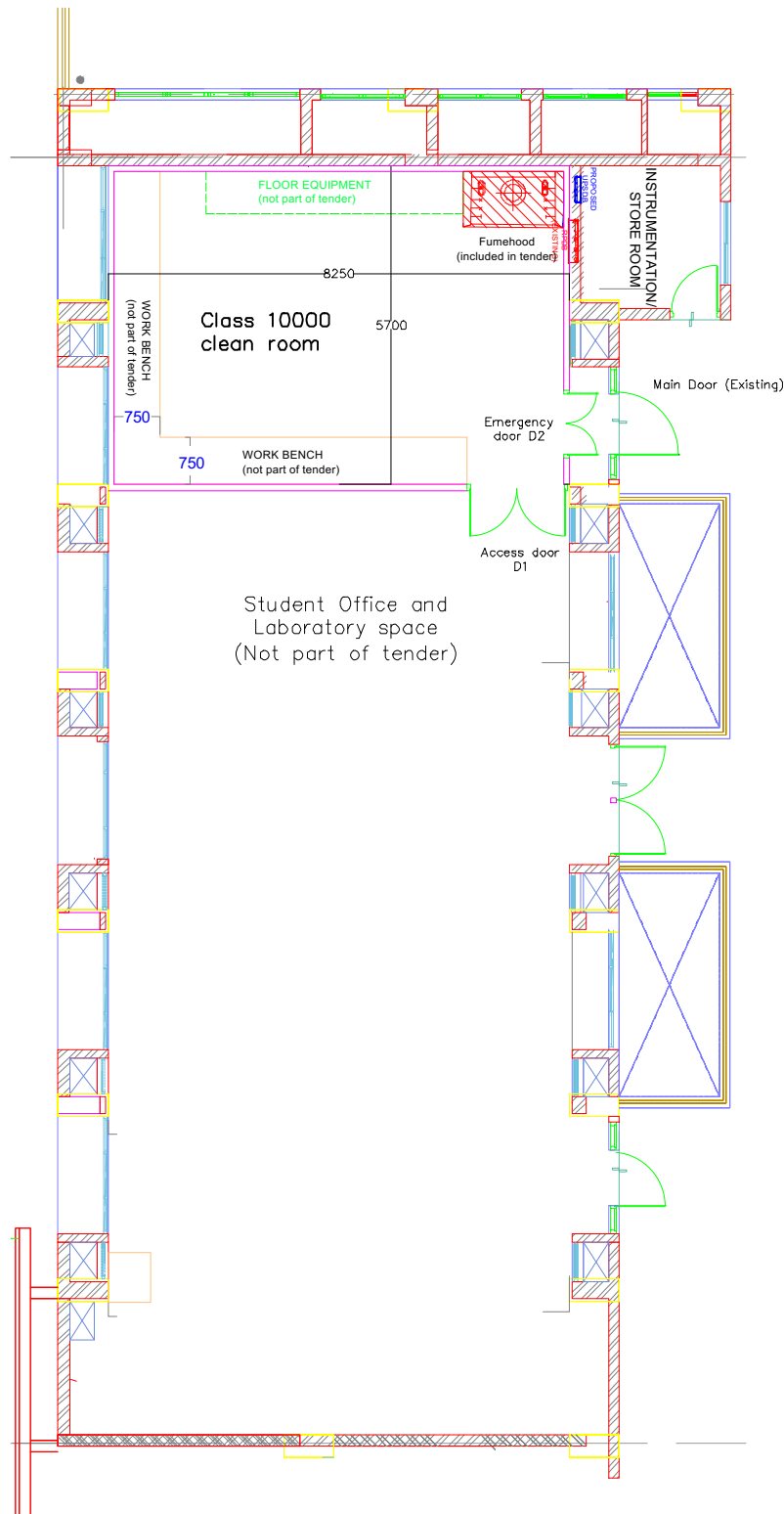

Check List to Be Submitted Along with Technical Bid

Please Attach Documents in the order given below.

S.No.	Section Title	Document Provided (Yes/No).	Document Page Number(s)
1.	Signed Check List for Technical Bid (this page)		
2.	Annexure-1: Details of the Bidder		
3.	Annexure-2:Declaration regarding experience		
4.	Annexure-3: Declaration regarding track record		
5.	Annexure – 4: Declaration for acceptance of terms and conditions		
6.	Annexure-5: Technical Compliance Sheet		
7.	Annexure-6: BOQ Class 1000 Clean Room (Note that pricing information SHOULD be masked)		
8.	Annexure-7: BOQ Class 10000 Clean Room (Note that pricing information SHOULD be masked)		
9.	Annexure 8: Make and Manufacturer Details		
10.	Masked Price Bid (Note that the pricing information should be masked)		
11.	Clean Room Layout Drawings for Class-1000 and Class-10,000 Cleanrooms		
12.	CAD Design Drawings for WCS-1 (see Technical Specifications II.5), WCS-2 (see Technical Specifications II.6) and Fumehood (see Technical Specifications III.5).		
13.	Technical specifications, Brochures and additional certifications where required		

I hereby declare all of the above requested documents are appended along with the technical bid. I understand that the bid will be considered unresponsive if any of the above requested information is missing. I also understand that any bids with pricing information in the technical bid documents will be considered unresponsive.

(Signature of the Bidder)

Printed Name

Designation, Seal Date:

Check List to Be Submitted Along with Commercial Bid

Please Attach Documents in the order given below.

S.No.	Section Title	Document Provided (Yes/No).	Document Page Number(s)
1.	Signed Check List for Commercial Bid (this page)		
2.	Annexure-6: BOQ Class 1000 Clean Room (Itemized pricing information with quantities is required)		
3.	Annexure-7: BOQ Class 10000 Clean Room (Itemized pricing information with quantities is required)		
4.	Commercial Bid		
5.	Costing Sheet for AMC for 2 years beyond the mandatory 3-Year warranty Period		
6.	Costing Sheet for consumables during the mandatory 3-year warranty period		

I hereby declare all of the above requested documents are appended along with the commercial bid. I understand that the bid will be considered unresponsive if any of the above requested information is missing.

(Signature of the Bidder)

Printed Name

Designation, Seal Date:

Annexure-1: Details of the Bidder

The bidder must provide the following mandatory information & attach supporting documents wherever mentioned:

Details of the Bidder

Sl. No	Items	Details
1.	Name of the Bidder	
2.	Nature of Bidder (Attach attested copy of Certificate of Incorporation/ Partnership Deed)	
3.	Registration No/ Trade License, (attach attested copy)	
4.	Registered Office Address	
5.	Address for communication	
6.	Contact person- Name and Designation	
7.	Telephone No	
8.	Email ID	
9.	Website	
10.	PAN No. (attach copy)	
11.	GST No. (attach copy)	

Signature of the Bidder

Name
Designation, Seal

Date:

Annexure-2: Declaration regarding experience

To,
The Chairman,
Solid State and Structural Chemistry Unit,
Indian Institute of Science,
Bangalore – 560012, India

Ref: Tender No:

Dated:

Sir,

I've carefully gone through the Terms & Conditions contained in the above referred tender. I hereby declare that my company / firm has years of experience in supplying and installing clean room infrastructure for semiconductor fabrication.

(Signature of the Bidder)

Printed Name

Designation, Seal Date:

Annexure-3: Declaration regarding track record

To,
The Chairman,
Solid State and Structural Chemistry Unit,
Indian Institute of Science,
Bangalore – 560012, India

Ref: Tender No:
Dated:

Sir,
I've carefully gone through the Terms & Conditions contained in the above referred tender. I hereby declare that my company/ firm is not currently debarred / blacklisted by any Government / Semi Government organizations / institutions in India or abroad. I further certify that I'm competent officer in my company / firm to make this declaration.

Or

I declare the following

Sl.No	Country in which the company is Debarred /blacklisted / case is Pending	Blacklisted / debarred by Government / Semi Government/Organizations /Institutions	Reason	Since when and for how long

(NOTE: In case the company / firm was blacklisted previously, please provide the details regarding period for which the company / firm was blacklisted and the reason/s for the same).

Yours faithfully
(Signature of the Bidder)

Name
Designation, Seal

Date:

Annexure – 4: Declaration for acceptance of terms and conditions

To,
The Chairman,
Solid State and Structural Chemistry Unit,
Indian Institute of Science,
Bangalore – 560012, India

Ref: Tender No:
Dated:

Sir,

I've carefully gone through the Terms & Conditions as mentioned in the above referred tender document. I declare that all the provisions of this tender document are acceptable to my company. I further certify that I'm an authorized signatory of my company and am, therefore, competent to make this declaration.

Yours faithfully,

(Signature of the Bidder)

Name

Designation, Seal

Date:

Annexure-5: Technical Compliance Sheet			
S.No.	Description	Complied? (Yes/No). Provide details about deviation if not in full compliance	Technical Documents Provided? (Yes/No/Not Applicable). Provide Page Numbers
I.1	The construction of clean room spaces must meet standard cleanroom specifications in addition to the specifications mentioned in this tender document.		
I.2	The clean rooms must maintain air quality, temperature and humidity specifications under normal usage with up to 5 users working simultaneously in addition to the specified equipment load.		
I.3	Installation should be modular to facilitate any changes that might be needed to accommodate new equipment in the future.		
I.4	User training on basic maintenance and troubleshooting must be provided.		
I.5	Materials used in the construction of clean room, fume hoods and clean room benches including but not limited to polypropylene should all be clean room fire retardant grade materials. The fire propagation index (FPI) and smoke development index (SDI) of relevant materials (especially polypropylene) being used in the design should be provided.		
I.6	ESD Flooring should be chosen such that the total resistance of the floor should be greater than 1 MΩ and less than 10 MΩ. Grounding of the floor is optional.		
I.7	<i>The vendor must use components/parts manufactured by the list of approved manufacturers only. If equivalent components from manufacturers that are not in the approved list are to be used, additional documentation providing enough evidence that all technical specifications are met should be enclosed along with the technical bid.</i>		

I.8	<p>The specifications/numbers/data provided in this technical document are to be taken for preparing a BOQ. The vendors should treat the specified quantities/numbers/data for various segments of the cleanroom and utility as a guideline to initiate their calculations. The vendors are supposed to provide IISc with an estimate of each and every component related to the cleanroom and its utility during their bid submittal. If the vendor estimates that higher quantities than requested are necessary, the excess should be quoted as an option. However, if the vendor estimates that lower quantities of a particular item are sufficient, the quotation should still include the costing for minimum requested quantities.</p>		
I.9	<p>Suitable clean room layout drawings should be provided along with the technical bid.</p>		
I.10	<p>Any additional construction for utilities placed on the terrace floor may be quoted as an option.</p>		
II.1.1	<p>Floor Area: ~25 sq. m. Refer appendix for floor plan (Section VI.1).</p>		
II.1.2	<p>Wall panels: The wall paneling must be modular, interlocking type and double skinned with both sides being powder coated GI (class-1000 clean room grade) with a skin thickness of at least 0.8 mm and powder coating thickness of 60 microns. Wall panels with built-in air raisers for extracting return air from the cleanroom are preferable. Such panels must be at least 100 mm in thickness with polyurethane foam (PUF) infilling with a density greater than or equal to 40 kg/m³. The panels must be reinforced along the periphery. Panels must be mounted and secured on suitable tracks. All joints must be sealed with cleanroom compatible neutral grade silicone sealant. All cut-outs must be covered with a suitable track. If wall panel design other than those with built-in air risers are provided, suitable technical or economy of cost justification must be given. In such alternate designs, skin thickness must be at least 0.8 mm and the powder coating thickness should be 60 microns or greater, and the panel thickness must be 50 mm or greater. The material of the panels must be clean-room compatible powder coated GI.</p>		

II.1.3	<p>Ceiling: The cleanroom ceiling must be at a height of 2500 mm or higher from the floor of the cleanroom. The ceiling height of the lab space housing the Class-1000 cleanroom is ~5250 mm. The ceiling paneling must be modular, and double skinned with both sides being powder coated GI (class-1000 clean room grade) with a skin thickness of at least 0.8 mm and powder coating thickness of at least 60 microns. The panels must be at least 50 mm thick with PUF infilling with a density greater than or equal to 40 kg/m³. The panels must be reinforced along the periphery and mounted on suitable tracks. All joints must be sealed with cleanroom compatible neutral grade silicone sealant. All cutouts must be covered with a suitable track.</p>		
II.1.4	<p>Flooring: The flooring must be anti-skid, hard wearing and electrostatic dissipative and sufficiently thick and dense to bear the weight of equipment. ESD specifications should meet criteria given in I.6. Each tile must be at least 12” X 12” in area, have an ESD material thickness of at least 3 mm. Vinyl as an ESD material is preferred.</p>		
II.1.5	<p>Covings: Clean room compatible Aluminum covings must be installed at corner joints of (a) Wall – Wall (b) Wall – Ceiling (c) Wall – Floor. All 3D corners must be installed and must be covered by 3D pieces. All covings must have sufficient conductivity to enable the dissipation of any electrostatic charge built-up on the floor and enable the total resistance to be in the range given in I.6. Other materials such as PVC will be acceptable with suitable justification.</p>		

<p>II.1.6</p>	<p>Emergency Doors: One double shutter door (marked as D1 in VI.1) with a width of 1400 mm (each door 700 mm wide) and 2400 mm in height is to be used for emergency exit and for any large equipment movement. The doors must be double skinned with both sides being powder coated GI (class-1000 clean room grade) with a skin thickness of at least 0.8 mm and powder coating thickness of at least 60 microns. The doors must be at least 44 mm in thickness with PUF infill (density > 40 kg/m³). The doors must be flush with the panels when closed and must be fixed to the door frames with concealed stainless-steel double bearing butt-hinges as per BS7352 specification. The doors must be provided with all required ancillaries like door closer, lock and key, D-handle, push plate, tower bolt all made of SS. Each door must be provided with a view glass of size 0.4m x 0.4m. All doors must open to the outside of the cleanroom and must be provided with a panic bar so that the doors can be quickly opened to exit the cleanroom in case of an emergency. The doors should have concealed type automatic door bottom seals.</p>		
<p>II.1.7</p>	<p>Access System: An RFID-based access system should be included. This should be configurable with existing ID cards. The details of the ID cards will be provided at the time of installation. This should be interlocked with an emergency alarm located outside the clean room. The cost for the installation of the emergency alarm is to be quoted.</p>		
<p>II.1.8</p>	<p>Window modules: Windows and door vision panels should be formed from double glazed toughened glass composite modules. One view panel (marked as W1 in VI.1) of size 900x900 mm shall be provided in the wall panels. View panel glass shall be at least 5 mm in thickness. View panels shall be fixed flush to both faces of wall panels. No crevices/joints/sloped profiles should be used for fixing the glass. This requirement is to avoid particle contamination and dust accumulation. All windows and door vision panels must filter light with a wavelength of <500 nm. (specification sheets/data sheets for the UV filters must be provided).</p>		

<p>II.1.9</p>	<p>A positive pressure airlock (refer VI.1 for dimensions and position) is to be provided at the cleanroom entrance. This is to also serve as a gowning area. The airlock must be constructed out of suitable class-1000 cleanroom compatible materials. It must be provided with access doors of 0.8 m width and 2.1m height that open outward i.e., out of the airlock (ref VI.1). A clean atmosphere, which is compatible for entry into a Class-1000 clean room, must be maintained inside the airlock. Clean air must be provided inside the airlock through hooded HEPA filters (hermetically sealed designs) or dedicated Fan Filter Units. The airlock must have interlocking doors so that only one door can be opened at a time. The locks must automatically disable when any emergency alarm in the cleanroom is triggered to enable quick evacuation of personnel. The airlock must be provided with necessary gown hangers, storage cabinet(s) etc for storing clean room gowns, masks, hairnets, clean room shoes, and other accessories. Suggested location and layout for the storage cabinet is shown in VI.1.</p>		
<p>II.2.1</p>	<p>Sufficient ultra-violet-filtered, ceiling mounted LED lighting must be provided through-out the cleanroom. All radiation below 500 nm must be blocked by the UV filters in the lighting systems. (specification sheets/data sheets for the UV filters must be provided). The lighting must be sufficient to provide 400 lux or greater illumination at 1 m from the cleanroom floor at all points inside the cleanroom. The illumination intensity must be demonstrated before commissioning. The lighting controls must be provided at user accessible locations inside the cleanroom near the user access door. The necessary fittings, wiring from distribution board and switches must also be supplied and installed. A suitable location for the switch board location that minimizes total wiring length can be chosen by the vendor</p>		
<p>II.2.2</p>	<p>32 numbers of 5/15 A single-phase power points and 4 numbers of 3-phase 32 A power points should be provided. These power points must be distributed over 5 lines each equipped with a suitable rated terminal circuit breaker (MCBs). Each of the power point must be labelled to indicate the line it is connected to. The MCBs are to be housed in a separate power distribution board inside the clean room. The distribution board must be constructed out of cleanroom compatible materials.</p>		

II.2.3	All motors and switchgears required for various items shall generally be all electric. Motors shall be suitable for 1 phase or 3 Phase, 50 Hz, 240 or 415 volts A.C. supply. The AC supply variability could be between +/- 10%. Therefore, the motors should withstand such load fluctuations. If the motor input is not suitable for power fluctuations, a voltage stabilizer should be provided. Electrical supply from electrical panel to respective AHUs/Condensing Units/Dehumidifier must use armored cables. Any underground cabling must be steel armored.		
II.2.4	All electrical wiring/cabling must be fire retardant and of a reputed make and must be sufficiently rated to handle the specified loads. The wiring/cabling must be routed through fire-retardant electrical conduits. Inside the clean room, the cables must be routed through appropriately sized fire-retardant PVC dado with partitions for routing cables and positioning power points separately.		
II.2.5	A suitably rated electrical panel must be provided and cables from AHU and other electrical units must be terminated at the panel. Copper lugs should be insulated for cable termination. All bus bars in the panel should be of copper. Incoming cabling termination at the electrical panel will be provided by IISc.		
II.2.6	All wires/cables must be color coded according to applicable electrical wiring standards. The wires must be labelled appropriately at the terminals. All electrical wiring diagrams/drawings with corresponding labels must be provided with installation documents.		
II.3.1	Gas distribution lines, one each for ultra-high pure Nitrogen, ultra-high pure Oxygen and ultra-high pure Argon must be installed. <i>Each gas line must be plumbed from a gas storage bay outside the cleanroom and terminated at a gas manifold inside the cleanroom with at least 3 output lines. Each output line at the manifold must have a diaphragm type shut off valve. The cost of fittings and piping for 5 meters per distribution line is to be included in the scope of this work (3 gas distribution lines with 5 meters per line).</i> As an option, the vendor must quote cost for laying any additional length of gas lines on a per foot basis.		

II.3.2	<p>The vendor must quote for supply and installation of components for connecting the 3 gas lines (as mentioned in II.3.1) to gas cylinders, as follows: Each gas line must have a flexible high-pressure SS hose (SS316L core and SS wire braided outer layer) 1 meter in length connected with a bull nose appropriate for each gas mentioned in section II.3.1 (bull nose should not have an O-ring seal). The bull nose must be connected to the hose through a non-return valve. The SS hose must be connected to a gas pressure regulator through a diaphragm type shut-off valve. The regulator must be of all stainless-steel construction capable of handling inlet pressure of 200 bar. Outlet pressure must be adjustable over 0-15 bar. A sample configuration is shown in figure 1. The regulator must be of barstock type with SS316L diaphragm. <u>All sealing materials used inside the regulators/shut-off valves must be clean room compatible and be also compatible with the particular gas type and purity grades.</u> The vendor must attach datasheets/specifications for the same.</p>		
II.3.3	<p>Gas tubing must be supported on channel mounted clean room compatible tubing support with provision to carry a total of 5 lines.</p>		
II.3.4	<p>Any unconnected lines must be appropriately terminated with suitable fittings.</p>		
II.3.5	<p>All support structures and fittings inside the cleanroom must be resistant to acids and common organic solvents and must be clean room compatible.</p>		
II.3.6	<p>All gas lines and accessories must be constructed out of high quality SS316L and must be of a reputed make. Compression type seals are acceptable, if compatible with clean room specifications. The RMS roughness of the inner body of the SS tubing must be 10 Ra or better.</p>		
II.3.7	<p>All gas lines must be leak-checked after installation.</p>		
II.3.8	<p>All gas lines must be labelled at appropriate intervals with clearly visible fade-proof labels easily readable by the user. The vendor must also provide drawings of the final gas plumbing layout.</p>		
II.4.1	<p>A dedicated recirculating-type Air handling unit/HVAC system must be provided for the class-1000 cleanroom</p>		
II.4.2	<p>The HVAC system must be designed to maintain the class-1000 clean room conditions as specified below:</p>		
	<p>1) Air purity: Particulate concentration of less than 1000 particles of size < 0.5 µm per cubic feet (Class-1000) according to ISO 14644,</p>		

	2) Room temperature of 22±2 °C		
	3) Relative humidity levels (RH) of 45±5%		
	4) Differential pressure of 15-20 Pa		
	5) Number of users: five users		
	6) Estimated equipment load: 6 kW (duty factor = 50% i.e., assume that the space has to be designed for an average equipment heat load of 3 kW)		
	7) Air flow pattern: Mixed Flow		
	8) Supply air Design: Negative pressure plenum type airflow using FFU with suitable HEPA filters or hooded HEPA filters-based design.		
	9) Supply air change rate: a minimum of 130 fresh air changes per hour		
	10) Supply air velocity: minimum 90 fpm ±20% (0.45 mps ±20%)		
	11) Filter coverage: minimum 30%		
	12) Fresh air changes per hour: a minimum of 3 fresh air changes per hour		
II.4.3	Air Handling Units (AHU) must be designed to meet specifications in II.4.1 and II.4.2. Fresh air intake must also take into account the exhaust of the fume hood specified in section II.5. AHU must be fitted with appropriate cooling coils, humidifiers, dehumidifiers, pre-filters etc., as required to maintain air temperature and humidity within specification II.4.2. Condenser unit must have a capacity of 6 TR or greater. Air heater module must also be appropriately rated. Only non-toxic, environment friendly refrigerants (R-407C or equivalent) may be used in the condenser units. Details of the refrigerant must be provided. All refrigerant piping and connectors must be made of copper and suitably insulated.		
II.4.4	Treated fresh air needs to be provided in order to compensate for any losses and to also maintain spatial positive pressure in the cleanroom. Precooling coils with suitable pre-filters, volume control dampers (VCDs), mixing box, heaters, mist eliminators etc., should be provided for the fresh air intake of the AHU.		
II.4.5	AHU must be installed on the roof of the building that houses the clean room. Approximate length of the ducting required is about 18 meters . The vendor may specify optional per meter cost for any extra ducting work.		

II.4.6	Clean air entry into the clean room portion may be either through hooded HEPA filters (hermetically sealed designs) or Fan Filter Units with a negative pressurized plenum. The standard operating cost of the design should be provided. Economical designs that decrease capital and operating costs will be given preference. Clear justifications showing the suitability of the adopted design is required. An air flow diagram must be provided with the technical bid.		
II.4.7	The filters in either of the units of II.4.6 should be modular in design and must be sourced from a reputed Original Equipment Manufacturer (OEM). Sufficient number of these units must be provided to maintain the cleanroom particulate and other specifications (specification II.4.2).		
II.4.8	All units must have HEPA filters manufactured by a reputed OEM. The filters must remove particulates bigger than 0.3 micron with 99.997% or greater efficiency (vendor must provide manufacturer specifications or supporting data). The quote must include details of the OEM. The units must also be equipped with prefilters to remove particulates bigger than 10 microns with 90% or greater efficiency.		
II.4.9	All unit enclosures must have a double skinned corrosion resistant enclosure with a thermal and acoustic insulating infill i.e. PUF of sufficient density (density > 40 kg/m ³). Enclosures must be provided with fire and smoke detectors and alarms, inspection doors and necessary inspection lighting. All mounts and frames for the indoor/outdoor units must be painted, be corrosion resistant and must be suitably padded to minimize vibration and noise.		
II.4.10	All ducting must be fabricated according to the latest SMACNA standards and must be cleanroom compatible. Air handling ducts and ducting joints must be made of corrosion resistant material that is resistant to any acid vapors and must have a minimum thickness of 24 gauge (~0.635mm) conforming to the latest SMACNA and cleanroom standards. The clause regarding acid resistance may be relaxed for portions, that the vendor has sufficient reason to believe, would never be exposed to acid vapors. However, the vendor must provide suitable drawings/documentation to support this. Ducting must be low noise and vibration free. All ducting/joints must be tested for leakage before commissioning and the leakage must be within the limits specified in the latest SMACNA standards.		

II.4.11	All ducting must be provided with sufficient thickness of insulation. The insulation must be fire retardant and aluminum faced. Provision must be made for internal cleaning of the ducting at appropriate locations.		
II.4.12	Any grills/diffusers used must be made of extruded anodized aluminum.		
II.4.13	All clamps/fastenings used for the ducting must be corrosion resistant.		
II.4.14	Alarms indicating any faults including fire and smoke alarms and alarms for detecting faults in the air handling system must be installed inside the cleanroom to alert users inside the cleanroom in case of any emergencies.		
II.4.15	An indicator/display unit for clean room temperature, RH and air handling system status along with a gauge showing the differential pressure of the cleanroom must be provided inside the cleanroom.		
II.5.1	Wet chemical station-1 (WCS-1) is meant for wet chemical processing using acids, bases and majorly aqueous solutions.		
II.5.2	WCS-1 should be composed of two parts:		
	<i>Part 1: 600x900x2400 mm (width x depth x height) fume hood with exhaust.</i>		
	<i>Part 2: 1200x900x2400 mm (width x depth x height) class-100 clean bench without exhaust.</i>		
II.5.3	WCS-1 must be constructed out of stress relieved high-quality polypropylene sheets of thickness 10 mm or thicker (data regarding residual stress must be provided). Any material being quoted must meet all clean room materials specifications as noted in 1.5. In addition, the material should be compatible with a variety of clean room solvents and photoresist/developer solutions used in a clean room. <i>A list of compatible solvents must be given.</i>		
II.5.4	The fumehood portion of WCS-1 must be provided with a clear transparent height adjustable counter-weight balanced sash made of acid and solvent resistant material that is at least 6mm in thickness. If this is a glass sash, it should be made of toughened laminated glass so that the glass does not shatter and fall to pieces in case of an explosion or breakage.		
II.5.5	The fumehood must have a standard value for face opening at full sash position. The sash opening at full sash position must be provided with the technical bid.		

II.5.6	The fumehood must maintain a face velocity between 90-110 fpm at half sash position. The fume hood exhaust blower must be suitably rated to maintain air flow rates and all ducting must be made of fire-resistant polypropylene. Fire resistance rating should be clearly mentioned. The quote should also include all necessary accessories, fittings for routing the exhaust duct and installation of the blower.		
II.5.7	The fumehood must have a flat 10 mm thick polypropylene worktop with a skirting of 10 mm height and 25 mm width to contain any spills on the worktop and prevent spilling on the floor. The worktop must be at a standard workable height from the cleanroom floor. The worktop height should be provided with the technical bid.		
II.5.8	One de-ionized (DI) water spray gun made of virgin PTFE with anti-static protection must be provided. This should be centrally located between the fume hood section and the clean bench section so that it is accessible for working in both the sections. The piping for the spray gun must be made of high-quality flexible polypropylene and must not leach contaminants into water (provide data or manufacturer specification sheets). When not in use, the piping must retract and be concealed inside the centrally located space between the fume hood and the clean bench. The piping must be sufficiently long so that the spray gun can reach all portions of the work tops in the fume hood and clean bench sections.		
II.5.9	One Nitrogen gun made of virgin PTFE with anti-static protection must be provided. The nitrogen blow gun should be centrally located between the fume hood section and the clean bench section so that it is accessible for working in both the sections. The piping for the nitrogen gun must be flexible, resistant to acids and common solvents and not outgas or generate particulates (provide specifications or manufacturer data sheet). The piping must have sufficient length to reach all portions of the work tops in the fume hood and the clean bench sections. When not in use, the extra piping must retract and be concealed inside the centrally located space between the fume hood and the clean bench.		
II.5.10	Gas supply lines for nitrogen from gas connection points, which are 3 meters from the fume hood and clean bench, should be included in the scope of work. These gas lines must be constructed from high-quality SS316L grade stainless steel tubing.		

II.5.11	<p>An in-line gas regulator rated to take an inlet pressure of 15 bar or higher and rated to provide an outlet pressure between 0-15 bar with outlet pressure indication, and a diaphragm type shut-off valve must be provided at an accessible location near the workstation. The pressure regulators are to be SS316L barstock type construction with SS316L diaphragms. All fittings must be suitable for gas pressure control of noncorrosive high purity gases up to grade 5.0 purity (99.999%).</p>		
II.5.12	<p>The part-2 of WCS-1 is a class-100 clean bench. The work area inside the clean bench must be maintained to meet specifications for a class-100 clean bench. Air must be circulated through suitable filters to maintain laminar down flow in the work area. A positive pressure must be maintained inside the work area to prevent contaminants from the room entering the work area. Acid vapors and particulates that may be present in the return air must be scrubbed before recirculation using suitable filters. <i>Details of suitable scrubbers, their specifications and maintenance schedule should be clearly given along with the technical bid.</i> The filter modules must use HEPA filters rated at better than 99.99% efficiency in removing particles bigger than 0.3 micron (provide manufacturer specifications or supporting data).</p>		
II.5.13	<p>The clean bench portion must be provided with a clear transparent height adjustable counter-weight balanced sash made of acid and solvent resistant material that is at least 6 mm in thickness. If this is a glass sash, it should be made of toughened laminated glass so that the glass does not shatter and fall to pieces in case of an explosion or breakage.</p>		
II.5.14	<p>The worktop must be made of 10 mm thick high-quality stress relieved perforated polypropylene sheets. A skirting of 10 mm height and 25 mm width must be provided to prevent any spillage of chemicals on the floor.</p>		
II.5.15	<p>The worktop of the clean bench must house one overflow type DI water bath with dimensions of 200 mm x 200 mm x 300 mm (length x width x depth). The overflow type de-ionized (DI) water bath should be made of stress relived high quality polypropylene and should be fully integrated into the clean bench. The top of the bath should be lower than the work top by at least 2 inches. The bath must be provided with a lid made of high-quality polypropylene so that it can be closed when not in use.</p>		

II.5.16	<p>When in use, DI water must continuously flow into the DI water bath and overflow out of the tank near the top of the bath. The overflow water must be collected and discharged through a drainpipe, preferably at a user settable flow rate between 1 <i>lpm</i> to 5 <i>lpm</i>. A shut-off valve must be provided to close the DI water supply when the bath is not in use. The bath must also be provided with an outlet near the bottom with a shut-off valve for draining the bath for routine cleaning. Both shut-off valves must be electronically controllable, ideally through a touch panel system that also shows the water resistivity and flow rate. The DI water bath is to be connected to the DI water supply system specified in section II.7.</p>		
II.5.17	<p>A main shut-off for DI water supply line and shut-off valves near the clean bench must be provided to shut-off DI water supply if required.</p>		
II.5.18	<p>Lighting with UV-filtering (to filter light with wavelength of <500 nm; specification sheets/data sheets for the UV filters must be provided) for an illumination level of 1000 lux or greater at worktop level on all points of the worktops, in the fume hood and the clean bench sections, should be provided.</p>		
II.5.19	<p>Magnehelic gauge of 50 mm of water column capacity to measure the differential pressure at the exhaust plenum box in fume hood portion of the workstation must be provided.</p>		
II.5.20	<p>Magnehelic gauge of 50 mm water column capacity to measure differential pressure inside work area of clean bench portion of the workstation must be provided.</p>		
II.5.21	<p>Three storage cabinet trolleys of 600 mm length each for chemicals/materials storage below the worktop. The trolleys must be made of high-quality polypropylene consistent with the specification in 1.5. One trolley under the fume hood (Part-1) and two trolleys under the clean bench (Part-2) parts of WCS-1 are required.</p>		

II.6.1	<p>The wet chemical station-2 (WCS-2) is a recirculating type ductless fumehood. Air from the cleanroom is drawn through the front over the work area and passed through suitable activated charcoal and HEPA particulate filters to remove any solvent vapors/particulates before discharging the air back into the cleanroom. The blower used must have sufficient capacity to maintain standard airflow rates. The internal airflow rates must be user controllable and a display must indicate the measured airflow speed. Lighting switches, air flow indicator and airflow controls must be provided on a control panel. <i>Details of filter specifications and maintenance schedule should be clearly given along with the technical bid.</i></p>		
II.6.2	<p>WCS-2 overall dimensions should be 1800 mm x 900 mm x 2400 mm (width x depth x height).</p>		
II.6.3	<p>WCS-2 must be constructed out of stress relieved high-quality polypropylene sheets of thickness 10 mm or thicker (data regarding residual stress must be provided). Any material being quoted must meet all clean room material specifications as noted in I.5. In addition, the material should be compatible with a variety of clean room solvents and photoresist/developer solutions used in a clean room. <i>A list of compatible solvents must be given.</i></p>		
II.6.4	<p>A clear, transparent height adjustable counter-weight balanced sash made of solvent resistant material that is at least 6 mm in thickness should be provided. If this is a glass sash, it should be made of toughened laminated glass so that the glass does not shatter and fall to pieces in case of an explosion or breakage. The sash material should be compatible with all clean room solvents similar to the requirements in II.6.2.</p>		
II.6.5	<p>The worktop must be made of 10 mm or thicker perforated high-quality polypropylene sheet. A skirting that is 10 mm high and 25 mm wide must be provided at the front of the worktop to contain any spills on the worktop and prevent spilling on the floor. The worktop must be at a standard workable height from the cleanroom floor. The worktop height being provided must be given with the technical bid.</p>		

II.6.6	One Nitrogen gun made of virgin PTFE with anti-static protection must be provided. The nitrogen blow gun should be centrally located so that it can be used throughout the working space of the solvent bench. The piping for the nitrogen gun must be flexible, resistant to common clean room solvents and not outgas or generate particulates (provide specifications or manufacturer data sheet). The piping must have sufficient length to reach all portions of the work top. When not in use, the extra piping must retract and be concealed inside the centrally located space between the fume hood and the clean bench.		
II.6.7	Gas supply line for nitrogen from gas connection points, which are 3 meters from the solvent workstation, should be included in the scope of work. These gas lines must be constructed from high-quality SS316L grade stainless steel tubing.		
II.6.8	An in-line gas regulator rated to take an inlet pressure of 15 bar or higher and rated to provide an outlet pressure between 0-15 bar with outlet pressure indication, and a diaphragm type shut-off valve must be provided at an accessible location near the workstation. The pressure regulator should be SS316 barstock type construction with SS316L diaphragm. All fittings must be suitable for gas pressure control of noncorrosive high purity gases up to grade 5.0 purity (99.999%).		
II.6.9	Lighting with UV-filtering (should filter out light with wavelengths of <500 nm; specification sheets/data sheets for the UV filters must be provided) for an illumination level of greater than 1000 lux at worktop level on all points of worktop inside the workstation should be provided.		
II.6.10	Magnehelic gauge of 50 mm of water column capacity to measure the differential pressure inside the working area of the workstation must be provided.		
II.6.11	At least two storage cabinets of at least 600 mm length each for chemicals/materials storage under the work top must be provided. At least one of the storage cabinets must be a 30-minute fire rated flammable materials storage cabinet rated to contain any fires for at least 30 minutes.		
II.6.12	A separate common polypropylene sink of size 450 x 400 mm with a drying area must be provided. It must have a polypropylene gooseneck with a tap and connected to the DI water supply line. The drain of the sink must be piped into the building drainage duct.		

II.7.1	<p>A de-ionized water system consisting of a generation and storage system for generating and storing Type-I (resistivity $\geq 18 \text{ M}\Omega\text{-cm}$) and Type-II water (resistivity $\geq 1 \text{ M}\Omega\text{-cm}$) should be provided. In addition to the resistivity metrics, the DI water system should comply with all Class-1000 clean room specifications. The vendor must design the system to meet all specifications and share the plant design and associated calculations. The vendor should also attach relevant specification sheets along with the technical bid.</p>		
II.7.2	<p>The DI water plant must be designed to support usage of upto 300 liters/day of Type-II water and upto 100 liters/day of Type-I water with peak usage of 10liters/minute for Type-I water and 10liters/minute for Type-II water (this does not include the usage by the Type-I water generator). The Type-II water generated is to be stored in a storage tank of suitable capacity. The water tank should be made of clean room grade polypropylene. The system must be equipped with an automatic cut-off to stop water generation once the storage tank is full. The Type-II water is to be used as feed water for the Type-I water system.</p>		
II.7.3	<p>The DI water plant along with the storage tank is to be installed in the utility area behind the lab space housing the cleanroom. The plumbing of Type-I water and Type-II water system to the respective distribution lines inside the cleanroom is to be included in the scope of the work. The piping set required to cover a distance of 10 meters between the DI generator and the POU (II.5 and II.6) inside the cleanroom is included in the scope of this work. As an option, the vendor may specify the cost of installing additional piping (if estimated to be greater than 10 m) on a per foot basis.</p>		
II.7.4	<p>The Type-II water distribution system is to be connected to the POU - DI water bath in wet chemical station-2 (section II.6) and must provide water at the specified flow rate. Type-I water distribution system is to be connected to POU spray gun installed in wet chemical station-1 (section II.5) and must provide water at 10 liters per minute at an output pressure of 1 bar at the spray gun outlet.</p>		
II.7.5	<p>The Type-I water system must continuously recirculate the water to provide constant fluid flow and eliminate dead legs to POU.</p>		
II.7.6	<p>Water quality monitors must be provided for live monitoring of the Type-I and Type-II water quality from the system. Resistivity sensors and display of measured resistivity value must be included.</p>		

II.7.7	The feed water is municipal supply water/borewell water or a mixture of the two. The feed water quality and pressure may vary. The vendor must provide appropriate pre-treatment/filter systems.		
II.7.8	Wastewater, if any, from the Type-I and Type-II systems should be connected to the building drain.		
II.7.9	The vendor must label all water supply lines with fade-proof easily readable labels at appropriate locations and must provide drawings and documentation of the final water plumbing layout.		
II.7.10	All electrical wiring and power points required for powering the DI plant is to be included in the scope of this work and must be done according to standards specified in section II.2.		
III.1.1	Floor plan: Floor Area: ~47sq. m. Refer appendix for floor plan (Section VI.2).		
III.1.2	Wall panels: The wall paneling must be modular, interlocking type and double skinned with both sides being powder coated GI (class-10000 clean room grade) with a skin thickness of at least 0.8 mm with a powder coating thickness of 60 microns or greater. Wall panels with built-in air raisers for extracting return air from the cleanroom are preferable. Such panels must be at least 100 mm in thickness with polyurethane foam (PUF) infilling with a density greater than or equal to 40 kg/m ³ . The panels must be reinforced along the periphery. Panels must be mounted and secured on suitable tracks. All joints must be sealed with cleanroom compatible neutral grade silicone sealant. All cut-outs must be covered with a suitable track. If wall panel design other than those with built-in air risers are provided, suitable technical or economy of cost justification must be given. In such alternate designs, skin thickness must be at least 0.8 mm and the powder coating thickness should be 60 microns or greater, and the panel thickness must be 50 mm or greater. The material of the panels must be clean-room compatible powder coated GI.		

III.1.3	<p>Ceiling: The cleanroom ceiling must be at a height of 2500 mm or higher from the floor of the cleanroom. The ceiling height of the lab space housing the Class-10000 cleanroom is ~5250 mm. The ceiling paneling must be modular, and double skinned with both sides being powder coated GI (clean room grade) with a skin thickness of at least 0.8 mm and powder coating thickness of at least 60 microns. The panels must be at least 50 mm thick with PUF infilling with a density greater than or equal to 40 kg/m³. The panels must be reinforced along the periphery and mounted on suitable tracks. All joints must be sealed with cleanroom compatible neutral grade silicone sealant. All cutouts must be covered with a suitable track.</p>		
III.1.4	<p>Flooring: The flooring must be anti-skid, hard wearing and electrostatic dissipative and sufficiently thick and dense to bear the weight of equipment. ESD specifications should meet criteria given in I.6. Each tile must be at least 12” X 12” in area, have a ESD material thickness of at least 3 mm. Vinyl as an ESD material is preferred.</p>		
III.1.5	<p>Covings: Cleanroom compatible Aluminum covings must be installed at corner joints of (a) Wall – Wall (b) Wall – Ceiling (c) Wall – Floor. All 3D corners must be installed and must be covered by 3D pieces. All covings must have sufficient conductivity to enable dissipation of any electrostatic charge built-up and enable the total resistance to be in the range given in I.6. Other materials such as PVC will be acceptable with suitable justification.</p>		

<p>III.1.6</p>	<p>Doors: (i) Double shutter door spanning a width of 1.7 m (each door 0.85 m wide) and 2.1 m height (marked D1 in VI.2) and (ii) One double shutter door spanning 1.1 m (each door 0.55 m wide) and 2.1 m height (marked D2 in VI.2). The doors must be double skinned with both sides being powder coated GI (class-10000 clean room grade) with a skin thickness of at least 0.8 mm and powder coating thickness of at least 60 microns. The doors must be at least 44mm in thickness with PUF infill (density > 40kg/m³). The doors must be flush with the panels when closed and must be fixed to the door frames with concealed stainless-steel double bearing butt-hinges as per BS7352 specification. The doors must be provided with all ancillaries like door closer, lock and key, D-handle, push plate, tower bolt all made of SS. Door D1 must be provided with a view glass of size 0.4m x 0.4m. All doors must open to the outside of the cleanroom and must be provided with a panic bar so that the doors be can quickly opened to exit the cleanroom in the case of an emergency. One leaf of door D1 is to kept closed during normal operations. The other leaf of D1 is meant for personnel access to the cleanroom and is to have an access control system. D2 is meant to be used as an emergency exit. All doors should have concealed type automatic door bottom seals.</p>		
<p>III.1.7</p>	<p>Access control: A biometric-based access system should be included. This should be configurable for multiple users. This should be interlocked with an emergency alarm located outside the clean room. The cost for the installation of the emergency alarm is to be quoted.</p>		
<p>III.1.8</p>	<p>Air curtains: Air curtains must be provided near the door D1 for preventing entry of particles from outside the cleanroom and must automatically turn on when a user enters the cleanroom.</p>		
<p>III.1.9</p>	<p>One safety eye shower must be provided inside the cleanroom at a suitable location.</p>		

III.2.1	<p>Sufficient ultra-violet-filtered, ceiling mounted LED lighting must be provided through-out the cleanroom. All radiation below 500 nm must be blocked by the UV filters in the lighting systems (specification sheets/data sheets for the UV filters must be provided). The lighting must be sufficient to provide 400 lux or greater illumination at 1 m from the cleanroom floor at all points inside the cleanroom. The illumination intensity must be demonstrated before commissioning. The lighting controls must be provided at user accessible locations inside the cleanroom near the user access door. The necessary fittings, wiring from distribution board and switches must also be supplied and installed.</p>		
III.2.2	<p>40 numbers 5/15A single-phase power points, 2 numbers 3-phase, 32A power points. These power points must be distributed over 5 lines each equipped with a suitable rated terminal circuit breaker (MCBs). Each of the power point must be labelled to indicate the line it is connected to. The MCBs are to be housed in a separate power distribution board inside the cleanroom. The distribution board must be constructed out of cleanroom compatible materials.</p>		
III.2.3	<p>All motors and switchgears required for various items shall generally be all electric. Motors shall be suitable for 3 Phase, 50 Hz, 415 volts A.C. supply. The AC supply variability could be between +/- 10%. Therefore, the motors should withstand such load fluctuations. If the motor input is not suitable for power fluctuations, a voltage stabilizer should be provided. Electrical supply from electrical panel to respective AHUs/Condensing Units/Dehumidifier must use armored cables. Any underground cabling must be steel armored.</p>		
III.2.4	<p>All electrical wiring/cabling must be fire retardant and of a reputed make and must be sufficiently rated to handle the specified loads. The wiring/cabling must be routed through fire-retardant electrical conduits. Inside the clean room, the cables must be routed through appropriately sized fire-retardant PVC dado with partitions for routing cables and positioning power points separately.</p>		
III.2.5	<p>A suitably rated electrical panel must be provided and cables from AHU and other electrical units must be terminated at the panel. Copper lugs should be insulated for cable termination. All bus bars in the panel should be of copper. Incoming cabling termination at the electrical panel will be provided by IISc.</p>		

III.2.6	All wires/cables must be color coded according to applicable electrical wiring standards. The wires must be labelled appropriately at the terminals. All electrical wiring diagrams/drawings with corresponding labels must be provided with installation documents.		
III.3.1	Gas distribution lines, one each for ultra-high purity Nitrogen, ultra-high purity Argon and ultra-high purity 5-10 % Hydrogen-in-Argon gas mixture must be installed. <i>Each gas line must be plumbed from a gas storage bay outside the cleanroom and terminated at a gas manifold inside the cleanroom with at least 3 output lines. . Each output line at the manifold must have a diaphragm type shut off valve. The cost of fittings and piping for 5 meters per distribution line is in the scope of work (3 gas distribution lines with 5 meters per line).</i> As an option, the vendor must quote the cost for laying any additional length of gas lines on a per foot basis.		
III.3.2	The vendor must quote for supply and installation of components for connecting the gas lines to gas cylinders described as follows: Each gas line must have a flexible high-pressure SS hose (SS316L core and SS wire braided outer layer) 1 meter in length connected with a <i>bull nose</i> appropriate for each gas mentioned in section III.3.1 (the bull nose should not have an O-ring seal). The bull nose must be connected to the hose through a <i>non-return valve</i> . The SS hose must be connected to a gas pressure regulator through a diaphragm type <i>shut-off valve</i> . The regulator must be of all stainless-steel construction capable of handling inlet pressure of 200 bar. Outlet pressure must be adjustable over 0-15 bar. A sample configuration is shown in figure 3. The regulator must be of barstock type with SS316L diaphragm from a reputed OEM. <u><i>All sealing materials used inside the regulators/shut-off valves must be cleanroom compatible and must also be compatible with the particular gas type and purity grades.</i></u> The vendor must attach datasheets/specifications for the same. Gas regulators and other components should be provided from the list of preferred OEMs, where provided.		
III.3.3	The plumbing of (i) UHP-Argon and (ii) 5-10 % Hydrogen-in-Argon gas mixture lines from the gas manifold up to the inlets of a glovebox housed inside the clean room to must be quoted. 10 meters of gas tubing must be quoted for each gas line. Any additional gas tubing must be quoted on a per foot basis, as an option.		

III.3.4	Gas tubing must be supported on channel mounted tubing support with provision to carry a total of 5 lines.		
III.3.5	Any unconnected lines must be appropriately terminated with suitable fittings.		
III.3.6	All support structures and fittings inside the cleanroom must be resistant to acids and common organic solvents.		
III.3.7	All gas lines and accessories must be constructed out of high quality SS316L and must be of a reputed make. Compression type seals are acceptable, if compatible with clean room specifications. The RMS roughness of the inner body of the SS tubing must be 10Ra or better.		
III.3.8	All gas lines must be leak-checked after installation.		
III.3.9	All gas lines must be labelled at appropriate intervals with clearly visible fade-proof labels easily readable by the user. The vendor must also provide drawings of the final gas plumbing layout.		
III.4.1	A dedicated recirculating type Air handling unit/HVAC system must be provided for the class-10000 cleanroom		
III.4.2	The HVAC system must be designed to maintain the class-10000 clean room conditions as specified below:		
	1) Air purity: Particulate concentration of less than 10000 particles per cubic feet (Class-10000) according to ISO 14644		
	2) Room temperature of 22±2 °C		
	3) Relative humidity levels (RH) of 45±5%		
	4) Differential pressure of 15-20 Pa		
	5) Number of users: five users		
	6) Estimated equipment load: 10 kW (duty factor = 50% i.e., assume that the space has to be designed for an average heat load of 5 kW).		
	7) Air flow pattern: Mixed Flow		
	8) Supply air Design: Negative pressure plenum type airflow using FFU with suitable HEPA filters or hooded HEPA filter-based design.		
	9) Supply air change rate: 60 air changes per hour		
	10) Supply air velocity: minimum 90 fpm ±20% (0.45 mps ±20%)		
	11) Filter coverage: minimum 15%		
	12) Fresh air changes per hour: 3		

III.4.3	<p>The Air Handling Units (AHU) must be designed to meet specifications in III.4.1 and III.4.2. Fresh air intake must also take into account the exhaust of the fume hood specified in section III.5. The AHU must be fitted with appropriate cooling coils, humidifiers, dehumidifiers, pre-filters etc. required to maintain the air temperature and humidity within specification III.4.2. The condenser unit must have a capacity of 5 TR or greater. The air heater module must also be appropriately rated. Only non-toxic, environment friendly refrigerants (R-407C or equivalent) may be used in the condenser units. Details of the refrigerant must be provided. All refrigerant piping and connectors must be made of copper and suitably insulated.</p>		
III.4.4	<p>Treated fresh air needs to be provided in order to compensate for any losses and also to maintain spatial positive pressure in the cleanroom. Precooling coils with suitable pre filters, volume control dampers (VCDs), mixing box, heaters, mist eliminators etc. shall be provided for the fresh air intake of the AHU.</p>		
III.4.5	<p>AHU must be installed on the roof of the building that houses the clean room. Approximate length of the ducting required is 14 meters. The vendor may specify optional per meter cost for any extra ducting work.</p>		
III.4.6	<p>Clean air entry into the clean room portion may be either through hooded HEPA filters (hermetically sealed designs) or Fan Filter Units suitably located in a negative pressurized plenum. The standard operating cost of the design should be provided. Economical designs that decrease capital and operating costs will be given preference. Clear justifications showing the suitability of the adopted design is required. An air flow diagram must be provided with the technical bid.</p>		
III.4.7	<p>The filters in either of the units of II.4.6 should be modular in design and must be sourced from a reputed Original Equipment Manufacturer (OEM). Sufficient number of these units must be provided to maintain the cleanroom particulate and other specifications (specification III.4.2).</p>		
III.4.8	<p>All units must have HEPA filters manufactured by a reputed OEM. The filters must remove particulates bigger than 0.3 micron with 99.997% or greater efficiency (vendor must provide manufacturer specifications or supporting data). The quote must include details of the OEM. The units must also be equipped with prefilters to remove particulates bigger than 10 microns with 90% or greater efficiency.</p>		

III.4.9	All unit enclosures must have a double skinned corrosion resistant enclosure with a thermal and acoustic insulating infill i.e. PUF of sufficient density ($> 40\text{kg/m}^3$). The enclosure must be provided with fire and smoke detectors and alarms, inspection doors and necessary inspection lighting. All mounts and frames for the indoor/outdoor units must be painted, be corrosion resistant and must be suitably padded to minimize vibration and noise.		
III.4.10	All ducting must be fabricated according to the latest SMACNA standards and must be compatible for the cleanroom classification. The air handling ducts and ducting joints must be made of corrosion resistant material that is resistant to any acid vapors and must have a minimum thickness of 24 gauge ($\sim 0.635\text{mm}$) conforming to the latest SMACNA and cleanroom standards. The clause regarding acid resistance may be relaxed for portions, that the vendor has sufficient reason to believe, would never be exposed to acid vapors. However, the vendor must provide suitable drawings/documentation to support this. The ducting must be low noise and vibration free. All ducting/joints must be tested for leakage before commissioning and the leakage must be within the limits specified in the latest SMACNA standards.		
III.4.11	All ducting must be provided with sufficient thickness of insulation. The insulation must be fire retardant and aluminum faced. Provision must be made for internal cleaning of the ducting at appropriate locations.		
III.4.12	Any grills/diffusers used must be made of extruded anodized aluminum.		
III.4.13	All clamps/fastenings used for the ducting must be corrosion resistant.		
III.4.14	Alarms indicating any faults including fire and smoke alarms and alarms for detecting faults in the air handling system must be installed inside the cleanroom to alert users inside the cleanroom in case of any emergencies.		
III.4.15	An indicator/display unit for clean room temperature, RH and air handling system status along with a gauge showing the differential pressure of the cleanroom must be provided inside the cleanroom.		
III.5.1	The fumehood is meant for wet chemical processing using organic solvents and de-ionized water and must be provided with an exhaust system.		

III.5.2	The overall dimensions of the fumehood are <i>1800x800x2400 mm (width x depth x height)</i> .		
III.5.3	The fumehood must be constructed out of stress relieved high-quality polypropylene sheets of thickness 10mm (data regarding residual stress in the sheets must be provided). Any material being quoted must meet all clean room materials specifications as noted in I.5. In addition, the material should be compatible with a variety of clean room solvents and photoresist/developer solutions used in a clean room. <i>A list of compatible solvents must be given.</i>		
III.5.4	The fumehood must be provided with a flat worktop made of 10mm thick polypropylene sheet. A skirting of width 25 mm and 10 mm height must be provided at the front of the worktop to contain any spills on the worktop and prevent spilling on the floor. It must include a polypropylene sink as specified in section III.5.11. The worktop must be at standard fumehood worktop height from the cleanroom floor. The worktop height should be provided with the technical bid.		
III.5.5	A clear transparent height adjustable counter-weight balanced sash made of acid and solvent resistant material that is at least 6mm in thickness. If this is a glass sash, it should be made of toughened laminated glass so that the glass does not shatter and fall to pieces in case of an explosion or breakage.		
III.5.6	The fumehood must have a standard value for face opening at full sash position. The sash opening at full sash position must be provided with the technical bid		
III.5.7	At fumehood must have standard fumehood face opening at full sash position and must maintain a face velocity between <i>90-110 fpm</i> at half sash position. The fumehood exhaust blower must be suitable rated and all ducting must be fire-resistant polypropylene. Fire resistance rating should be clearly mentioned. The quote should include all necessary fittings for routing the exhaust duct and installation of the blower.		

III.5.8	Two Nitrogen guns made of virgin PTFE with anti-static protection must be provided at each end of the fumehood worktop. The nitrogen blow guns must have a filter housing with disposable filters. The piping for each of the guns must have enough length to reach the whole of the work area. When not extended, the extra piping must retract and be concealed inside the workstation body. The piping must be resistant to acids and common solvents and must not outgas or generate particulates (provide specifications/manufacturer data sheets with quote)		
III.5.9	One Gas supply line for nitrogen from gas connection points, which are 3 meters from the fume hood, should be included in the scope of work. These gas lines must be constructed from high-quality SS316L grade stainless steel tubing.		
III.5.10	A gas line regulator rated at 0-15 bar with line and outlet pressure indication and a diaphragm-type shut-off valve must be provided on the gas supply line to control the pressure of the nitrogen at an accessible location near the workstation. The pressure regulators must be SS316L barstock type construction with SS316L diaphragm. All fittings must be suitable for pressure gas control of noncorrosive, high purity gases up to grade 5.0 purity (99.999%).		
III.5.11	A polypropylene sink with 250 x 200 mm must be provided inside the fumehood at back left corner. It must have a polypropylene gooseneck with a tap and connected to the DI water supply line. The drain of the sink must be piped into the building drainage duct.		
III.5.12	Lighting with UV-filtering to filter light with wavelength of <500 nm (specifications or manufacturer data sheets must be provided) for an illumination level of 1000 lux or greater at worktop level on all points of the worktops, in the fume hood and the clean bench sections, should be provided.		
III.5.13	Magnehelic gauge of 50mm of water column capacity to measure the differential pressure at the exhaust plenum box in part-1 (fume hood) of the workstation must be provided.		
III.5.14	Two storage cabinet trolleys of 900mm length each for chemicals/materials storage under fumehood. The trolleys must be made of high-quality polypropylene.		
V.1	The vendor is responsible for the design, supply, commissioning and validation of the cleanrooms and all utilities/equipment covered under the contract.		

V.2	The electrical system installation shall be carried out by qualified electricians either employed or contracted by the vendor.		
V.3	The vendor must arrange for materials unloading and staging.		
V.4	The vendor must demonstrate that the performance and quality parameters of the cleanroom and equipment comply to the specifications. Following performance tests must be carried out at three occupancy states: as-built, at-rest, and operational.		
	a) Air-borne particle count for ultrafine particles		
	b) Airborne particle count for macro-particles		
	c) Airflow test, air velocity measurement, leakage test, room pressurization test		
	d) Air pressure difference test		
	e) Temperature test		
	f) Humidity test		
	g) Illumination level measurement according to DIN 5035		
	h) Recovery test		
V.5	The vendor shall supply cleanroom certifications complying with ISO 14644 requirements.		
V.6	The price quotation should include the cost of installation, validation and training of potential users (about 5 users per clean room).		
V.7	The system should be provided with at least 3-years of warranty , on all parts and labor, from the date of installation.		
V.8	The vendor must provide routine maintenance of the cleanroom and associated equipment that is part of this tender.		
V.9	The vendor should have a track record of having previously supplied and installed at least five cleanroom systems in India with similar specifications. Details of such systems should be provided.		
V.10	The vendor should have qualified technical service personnel for the equipment based in India and should assure a response time of less than 48 hours.		
V.11	Vendor must provide a user list (with contact details including emails and phone numbers) of at least 5 customers from Indian Institutes/Labs where similar systems have been installed.		
V.12	The lead-time for the delivery of the equipment should not be more than 6 months from the date of receipt of our purchase order.		

V.13	The indenter reserves the right to withhold placement of final order. The right to reject all or any of the quotations and to split up the requirements or relax any or all of the above conditions without assigning any reason is reserved.		
V.14	Wherever requested data must be supplied along with technical compliance documents. Technical bids without supporting data will be deemed as technically non-compliant.		
V.15	All guaranteed specifications will have to be demonstrated at the time of installation. Any necessary standard samples for that purpose should be brought by the service engineers.		
V.16	Printed literature and published papers in support of all compliance to the prescribed specifications may be provided.		
V.17	The vendor must provide compliance statement in a tabular form with respect to each technical specification in the tender document duly supported by the manufacturer's literature and published papers. Any other claim will not be accepted and may lead to rejection of the bid.		
V.18	Technical evaluation by the institute may include demonstration to verify functionalities and capabilities of the system quoted. Any discrepancy between the promised specifications and measurements will be deemed as technical non-compliance.		
V.19	The vendor must quote for a non-comprehensive AMC price beyond the 3-year warranty period, with a price lock in for 2 years beyond the standard 3-year warranty period. 2 services per year should be included in the AMC.		
V.20	The quote should also include additional spares sufficient for three years of system usage assuming an average usage of 120 hours of operation per week.		
V.21	The Bidder's firm should have existence for a minimum of 3 years. Enclose Company Registration Certificate and balance sheet of last three years.		
V.22	The Bidder should belong to either class 1 or class 2 supplier distinguished by their "local content" as defined by recent edits to GFR. They should mention clearly which class they belong to in the cover letter		
	a) Class 1 supplier: Goods and services should have local content of equal to or more than 50%.		
	b) Class 2 supplier: Goods and services should have local content of equal to or more than 20 % and less than 50%.		

	Purchase preference as defined by the recent edits to GFR (within the “margin of purchase preference”) will be given to Class-1 supplier.		
V.23	The bidder should sign and submit the declaration for Acceptance of Terms and Conditions as per -Annexure 4.		
V.24	The Bidder must not be blacklisted/banned/suspended or have a record of any service-related dispute with any organization in India or elsewhere. A declaration to this effect has to be given as per Annexure 3.		

Annexure-6: BOQ Class 1000 Clean Room (Note that pricing information SHOULD be masked when submitting this annexure with Technical Bid)							
Provide details about the Unit and Quantity							
S.No.	Item Description	Unit	Quantity	Unit Supply Cost (Rs.)	Total Supply Cost (Rs.)	Installation Cost (Rs.)	Total Cost (Rs.)
1	Wall Panels complying with Section II.1.2						
2	Return Air Riser Panels complying with Section II.1.2 (if being used)						
3	Supply and Return Air Diffuser, if applicable, and complying with II.1.2						
4	Celing Panels complying with Section II.1.3						
5	Flooring complying with II.1.4						
6	Covings (wall to wall, wall to ceiling and wall to floor) complying with II.1.5						
7	HEPA Filter Modules and Fan Filter Units, as applicable, and complying with II.1.9 and II.4						
8	Emergency Door complying with II.1.6						
9	An RFID Access System complying with II.1.7						
10	Window Module complying with II.1.8						
11	Positive Pressure Airlock complying with II.1.9						

12	Lighting and Electricals complying with II.2						
13	Gas Lines and Accessories complying with II.3						
14	HVAC System complying with II.4						
15	WetChemical Station-1 complying with II.5						
16	WetChemical Station-2 complying with II.6						
17	DI Water System complying with II.7						

Annexure-7: BOQ Class 10000 Clean Room (Note that pricing information SHOULD be masked when submitting this annexure with Technical Bid)							
Provide details about the Unit and Quantity. Please itemize where necessary.							
S.No.	Item Description	Unit	Quantity	Unit Supply Cost (Rs.)	Total Supply Cost (Rs.)	Installation Cost (Rs.)	Total Cost (Rs.)
1	Wall Panels complying with Section III.1.2						
2	Return Air Riser Panels complying with Section III.1.2 (if being used)						
3	Supply and Return Air Diffuser, if applicable, and complying with III.1.2						
4	Celing Panels complying with Section III.1.3						
5	Flooring complying with III.1.4						
6	Covings (wall to wall, wall to ceiling and wall to floor) complying with III.1.5						
7	HEPA Filter Modules and Fan Filter Units, as applicable, and complying with III.4						
8	Clean Room Door(s) complying with III.1.6						
9	An RFID Access System complying with III.1.7						
10	An Air Curtain complying with III.1.8						
11	An eye shower complying with III.1.9						
12	Lighting and Electricals complying with III.2						
13	Gas Lines and Accessories complying with III.3						
14	HVAC System complying with III.4						
15	Fumehood Complying with III.5						

Annexure 8: Make and Manufacturer Details				
Provide details about the Make/manufacturer details for the following items				
S.No.	Item Description	Approved Makes	Make being quoted	Is the technical Certificate attached if there is a deviation and Page No. for the certificate
I	Clean Room Construction			
I.1	Air Curtain for class-10000 clean room entrance	ALMONARD/ FABTECH/ I-CLEAN		
I.2	Wall panels, Ceiling panels and mounting systems	PLASCORE / CHANNEL SYSTEMS/ VERO VERIA/ RITTERWAND/ FLEXICON/ AMERICAN CLEANROOM SYSTEMS		
I.3	UV filter films for door vision panels and windows	UV PROCESS SUPPLY USA/ DURXTREME GMBH/ ASMETEC GMBH		
I.4	Antistatic vinyl flooring tiles	FORBO/ STATCLEAN/ TARKETT/ WONDERFLOOR/ GERFLOR/ DOY YEE		
I.5	RH and temperature indicator	WAREE/ HTA		
I.6	Magnahelic gauge	WAREE/ DWYER/ SENSOCON		
I.7	Emergency eye wash	KLENZAIDES/ I-CLEAN/ GMP/ CRP/ FAB TECH		
II	Air handling systems			
II.1	Air Handling Units	EDGETECH/ ZECO/ SYSTEMAIR/ FLAKTWOOD/ CITIZEN/ I-CLEAN		
II.2	AHU Fan blower	NICOTRA/ KRUGER/ FLAKTWOODS		
II.3	Motors for AHU	CROMPTON GREAVES/ ABB/ SIEMENS /KIRLOSKAR (motors shall be the highest star rated category as per bee)		
II.4	Motor Soft starter	SIEMENS/ ABB/ L&T/ SCHNEIDER		

II.5	Fan Filter Units/HEPA filters for Class-1000 and Class-10000	CAMFIL/ AAF/ CFS/ FREUDENBERG/ EGCLEANTECH/ UNIFIL		
II.6	Chiller unit	YORK/ CARRIER / TRANE/ CLIMAVENTA		
II.7	Chiller Motors	ABB/ SIEMENS/ CROMPTON GREAVES		
II.8	Chilled / Condenser Water Pipes	SAIL/ TATA/ JINDAL		
II.9	Globe Valve/ Gate Valve/ Check valve	CASTLE/ ADVANCE/ AUDCO/ ALFA LAVAL/ LEADER		
II.10	Butterfly Valve	AUDCO / L&T/ KIRLOSKAR/ ADVANCE/ BELIMO/ CASTLE		
II.11	3 Way Control/ Mixing Valve	HONEYWELL/ SIEMENS/ BELIMO		
II.12	Balancing Valves/ Flow Measuring devices	BELL & GOSSETT/ TOUR & ANDERSON/ ANERGY/ SIEMENS/ ADVANCE		
II.13	Water flow Switch	HONEYWELL/ SIEMENS/ BELIMO		
II.14	Ducting – GI sheets	SAIL / JINDAL / TATA		
II.15	Flexible duct	ATCO/ GP SPIRO/ ROLASTAR		
II.16	Duct Insulation	ARMAFLEX/ K- FLEX/ SUPREME/ TROCELLENE/ ARMACELL		
II.17	Magnehelic gauges	WAREE/ DWYER/ SENSOCON		
II.18	Damper Actuators	HONEYWELL/ SIEMENS/ BELIMO		
II.19	Grilles/ Diffusers/ VCD/ Ducting fittings	AIR MASTER/ CARYAIRE/ AJANTA/ SYSTEM AIR / FLAKTWOOD/ COSMOS/ RUSKIN TITUS		
II.20	Temperature/ RH/ Pressure Sensors (Cleanroom)	HONEYWELL/ SIEMENS/ JOHNSON		
II.21	Pressure gauges	WIKA/ FORBES MARSHALL		
II.22	RH and temperature indicator	WAREE/ HTA		
II.23	Thermostats/ Humidistat	SAUTER/ SIEMENS/ JOHNSONS/ HONEYWELL		

II.24	Dehumidifiers	BRY-AIR/ MUNTERS/ WHITE WASHINGHOUSE/ APPIDI/ AIR PACK		
II.25	Pan type humidifier	RAPID COOL/ NORDAMANN/ WALTER MEIER/ APPIDI/KEPL		
II.26	Electrical Strip Heaters	HEATCON/ DASPASS/ ESCORTS/RAPID COOL/KEPL		
II.27	Electrical LT Panels as per IEC 61439-1	LEGRAND/ SCHNEIDER ELECTRIC / SIEMENS / ABB /L&T or their authorized franchisees/ system integrators		
II.28	MCCB	SIEMENS/ SCHNEIDER/ ABB / L&T / LEGRAND		
II.29	MCB	SIEMENS/ SCHNEIDER/ ABB / L&T / CG / HAGER / INDO ASIAN		
II.30	Power/ Control Contacts, Overload Relays, Timers, etc.	SIEMENS/ SCHNEIDER/ ABB / L&T		
II.31	Fuses	SIEMENS/ SCHNEIDER/ ABB / L&T		
II.32	Power Cables/ Control Cables/ Wires	FINOLEX/ UNIVERSAL/ POLYCAB/ UNISTAR/ NICCO / RAVIN		
III	Fumehood/ Wet chemical station			
III.1	Blower motors for fumehood, ductless fumehood, cleanbench etc.	CROMPTON GREAVES/ ABB/ SIEMENS /KIRLOSKAR (Motors shall be the highest star rated category as per bee)		
III.2	Fan Filter Units/HEPA filters for Class 100 clean benches	CAMFIL/ AAF/ CFS/ FREUDENBERG/ EGCLEANTECH/ UNIFIL		
III.3	Magnehelic gauges	WAREE/ DWYER/ SENSOCON		
III.4	Gas pressure regulator	SWAGELOK/ GCE/ SANDVIK/ VALEX/ DOCKWEILER		
III.5	Gas Piping and fittings	SWAGELOK/ GCE/ SANDVIK/ VALEX/ DOCKWEILER		
IV	Gas Lines and Accessories			

IV.1	SS tubing	SWAGELOK/ GCE/ SANDVIK/ VALEX/ DOCKWEILER		
IV.2	Regulators	SWAGELOK/ MATHESON/ GCE/ HALEHAMILTON/ MESSER		
IV.3	Valves	SWAGELOK/ MATHESON/ GCE/ VALEX, TK-FUJIKIN/ DOCKWEILER		
IV.4	Fittings, flexible high- pressure hoses, tubing mounts etc.	SWAGELOK, MATHESON, GCE, DOCKWEILER		
V	Lighting and electrical			
V.1	Lighting – LED	PHILIPS /OSRAM		
V.2	Electrical LT Panels as per IEC 61439-1	LEGRAND/ SCHNEIDER ELECTRIC / SIEMENS / ABB /L&T OR THEIR AUTHORIZED FRANCHISEES/ SYSTEM INTEGRATORS		
V.3	MCB distribution boards	LEGRAND, SIEMENS, CROMPTON, HAVELLS		
V.4	LT cables	NICCO/UNIVERSAL/ FINOLEX		
V.5	Power Cables/ Control Cables/ Wires	FINOLEX/ UNIVERSAL/ POLYCAB/ UNISTAR/ NICCO / RAVIN		
V.6	Electrical conduits	POLYCAB/ AVONPLAST / SUDHAKAR/ PRECISION/AKG		
V.7	Switches/Sockets	ANCHOR/ MK/ LEGRAND/ ABB/CRAB TREE/ SCHNEIDER ELECTRIC		
V.8	MCBs	SIEMENS/ SCHNEIDER/ ABB / L&T / CG / HAGER / INDO ASIAN		
V.9	MCCB	SIEMENS/ SCHNEIDER/ ABB / L&T / LEGRAND		
VI	De-ionized water system			
VI.1	DI water system	EVOQUA WATER TECHNOLOGIES/ MILLIPORE /KOMAL / GRAUER &WEIL, / PURELAB-ELGA /		

VII	Safety and access control			
VII.1	Fire/smoke detection and alarm systems	NOTIFIER / SIEMENS / GE / APOLLO (UL CERTIFIED ONLY)		
VII.2	Safety Eye Shower	PAL BAM / TERRA UNIVERSAL /NUAIRE/ CLEAN ZONES /ROTH		
VII.3	Access control and emergency systems	SIEMENS / BOSCH / HONEYWELL		